

UDC 621.875

THE METHODOLOGICAL PECULIARITIES OF THE INVESTIGATION OF PORTAL CRANE ROLLED STEELS DEGRADATION

Oleksandr Nesterov

Odesa National Maritime University, Odesa, Ukraine

Summary. *Rolled structural steels of port structures, operating under intensive cyclic loading, are particularly susceptible to the degradation of their mechanical properties. Advantages of the investigation of operational degradation of steels based not on fatigue strength characteristics, but on characteristics of resistance to brittle fracture using the example of determining the impact strength of longitudinal and transverse Charpy samples in relation to the rolling direction of sheet metal for 10 local areas at different structural nodes of portal crane are analyzed. This is caused to a great extent by micro-layering along the stretched fibers in the rolling direction of the rolled product. Accordingly, the mechanical properties of the metal become particularly sensitive to the direction of samples cutting in relation to the direction of rolling. Therefore, in order to evaluate the steel operational degradation it is recommended to use transverse samples in which the direction of micro-layering coincides with the direction of rolling. Possible role of the marine environment in enhancing the degradation of steel due to its flooding properties is also considered in this paper.*

Key words: *portal crane, rolled steel, in-service degradation, brittle fracture resistance, delamination.*

https://doi.org/10.33108/visnyk_tntu2023.01.066

Received 26.01.2023

The most common type of transshipment machines in seaports are portal cranes and transshipment cranes, due to which the main part of loading and unloading operations is carried out. Their safe long-term operation is an important scientific and technical problem [1, 2]. Mechanical structures operate in the mode of multi-cycle loading, which is the main factor in significant degradation of the initial mechanical properties, and hence the high risk of crane destruction [3]. This problem is the most important one for cranes with overtime period of operation, because it is just for them the defects of fatigue nature are most often detected, as harbingers of unpredictable destruction [4, 5], resulting in serious consequences.

Taking into account the fact that it is cyclic loading that causes operational degradation of structural steels of portal cranes, the approaches based on the determination of metal fatigue properties are used to evaluate and predict their mechanical behavior [6]. They refer both to the stage of crack initiation and to the stage of its propagation. At the same time, the use of impact viscosity as the characteristic of resistance to brittle fracture is effective for this purpose [5]. It is determined that cases of accidental destruction or significant fatigue damage match the metal with particularly low values of impact strength (14...30 J/cm²). On the other hand, this is sufficiently regulated mechanical characteristic in regulatory documents, which is relatively easy determined experimentally and the current level of which can be predicted using non-destructive control methods, including electrochemical methods [7, 8].

The investigation of operational rolled steels degradation has certain features associated with micro-layering along the rolling direction of the rolled product, increasing the differences in the mechanical properties cut along and across the rolling [9, 10].

The methodological features of the investigations of operational degradation of mechanical properties of rolled low-carbon steels of load-bearing structures of portal cranes are summarized in this paper.

The impact strength of Charpy samples is considered as particularly sensitive to operational degradation of structural steels [11], despite the fact that they operate in the mode of multi-cycle loading. This substantiation is demonstrated on the example of the determination of *KCV* impact strength of longitudinal and transverse Charpy samples in relation to the rolling direction of the rolled sheet. The state of «Sokil» brand portal crane is investigated after 33 years of operation, the construction material is rolled sheet low-carbon ferritic-pearlite brand steel St-38b-2, the domestic analogue is St.3sp steel. 10 local areas are selected at various crane structural nodes (Fig. 1). The sheet material has different thickness t . On the one side, the cyclic stress σ_e , varying within the range of 45...145 MPa, is determined on them by tensometric-calculation method under certain model conditions. On the other side, it is possible to cut longitudinal and transverse samples in relation to the rolling direction of the rolled product in order to determine the level of impact strength by Charpy method. The table shows the correlation between the level of impact strength and predicted level of operational cyclic stresses is shown in the Table. In general, the higher is the stresses σ_e , the lower is the resistance to brittle fracture of steel.

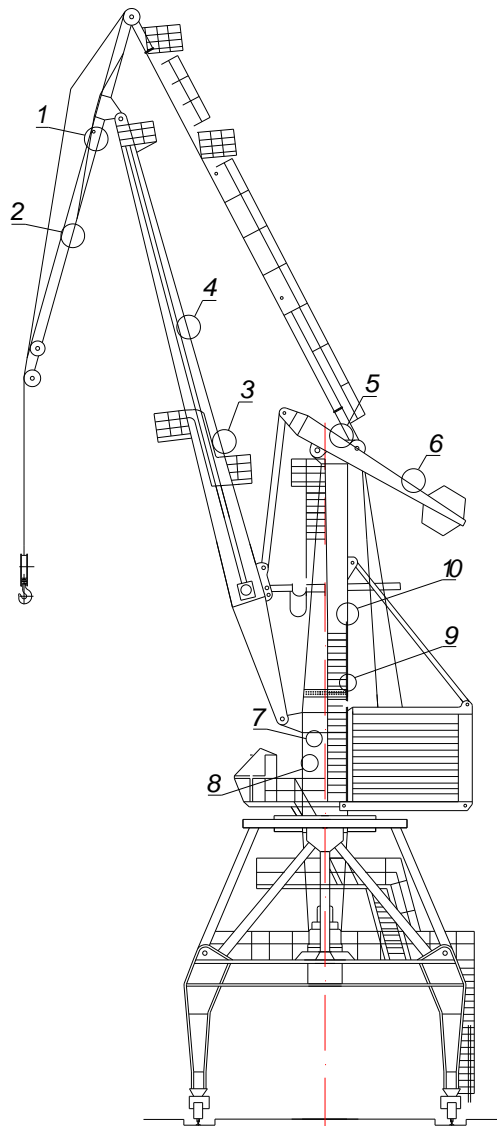

Figure 1. Schematic image of «Sokil» portal crane with specified areas of metal for investigations:
 1, 2 – the lower shelf of the trunk; 3, 4 – the back shelf of the boom; 5, 6 – the upper shelf of the rocker arm;
 7, 8 – the left wall of the column; 9, 10 – the back wall of the column

It should be noted that the cyclic load of structures is characterized by certain static component of the load, that is, the coefficient of asymmetry of cycle $R > 0$. In our analysis, this factor is not taken into account, although it is obvious that the material from different local areas is characterized by different value of parameter R . On the other hand, the factor of cyclic loading, characterized by σ_e indicator, correlates with corresponding changes in the fracture strength level, which indicates the effectiveness of using the brittle fracture resistance indicator in evaluating the operational degradation of transshipment equipment.

Table 1

Impact strength of steel of different crane nodes under different cyclic stress σ_e .

No	Crane node	t , mm	σ_e	KCV , J/sm ² , samples	
			MPa	Transverse, KCV_l	Longitudinal, KCV_c
1	The lower shelf of the trunk	16	130	60	159
2			110	95	220
3	The rear shelf of the boom	12	48	114	299
4			55	123	310
5	The upper shelf of the rocker arm	10	45	127	303
6			50	177	363
7	The right wall of the column	10	120	45	150
8			145	53	189
9	The back wall of the column	25	70	125	227
10			100	137	312

Marine port structures are exposed to the influence of marine environment, so they are protected from corrosion by paint coatings. However, not all areas of constructions, often with complex geometry, can be reliably protected from corrosion, and with operation time, the coatings lose their functional properties. However, during such analysis we should take into account the fact that marine environment can also be characterized by hydrogenated properties [12, 13], resulting in the intensification of operational degradation of steels, first of all, by the mechanism of microdamage development, including microdelamination between the fibers of metal texture or at the boundaries between the matrix and drawn non-metallic inclusions.

On the other hand, it should increase the differences in the values of impact strength depending on the direction of samples cutting in relation to the direction of rolling. The corresponding data for steels of the investigated crane areas and two separate dependencies for different ranges of sheet thickness are shown and determined in Fig. 2. Thus, the ratio KCV_c / KCV_l changes within the range of 0.37...0.55 for t from 16 to 25 mm, then for thicknesses of 10 and 12 mm within the range of 0.28...0.42. The obtained results can be explained precisely by the hydrogenated ability of marine atmosphere, under which operational degradation of steel takes place under the combined action of mechanical stresses and hydrogen absorbed by the metal. It is known that the destructive role of hydrogen can occur due to the recombination in defects of the structure of atomic hydrogen into molecular one with the creation of high gas pressures and, respectively, stresses commensurate with the strength characteristics of steels [14].

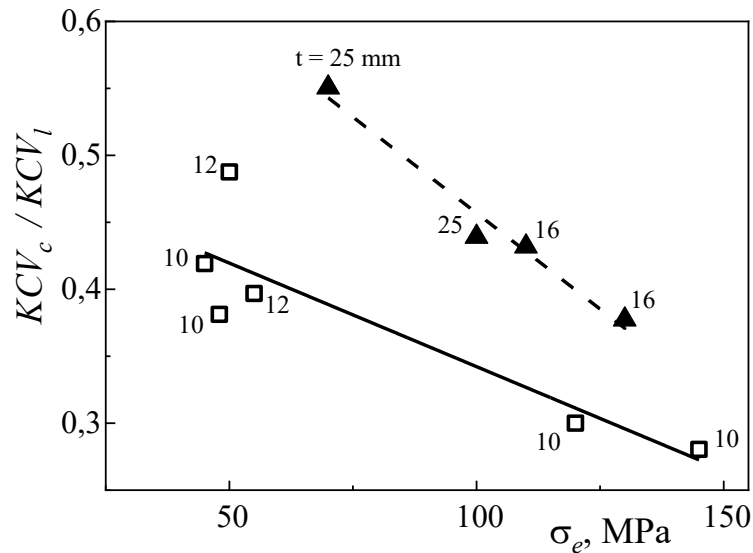

Figure 2. Relationship between the impact strength of transverse KCV_c and longitudinal KCV_l samples depending on the stress σ_e for rolled sheets with different thicknesses

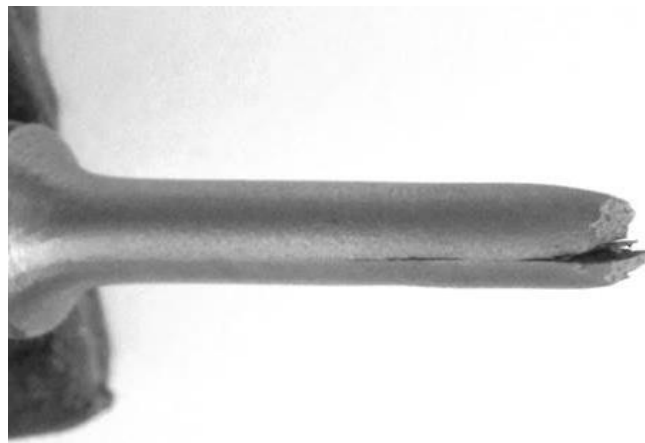

Figure 3. General view of the destroyed longitudinal tensile sample made from the lower shelf of the trunk, pos. 1 in Fig. 1 and in the Table

Such significant differences in the values of impact strength depending on the direction of samples cutting relative to the rolling direction of the rolled sheet indicate the advantage of using transverse samples while evaluating the operational degradation of port structures steels, particularly, portal cranes.

Operational intensification of layering is also confirmed by tensile tests of cylindrical samples for the determination of mechanical properties of strength and plasticity. We observed delamination along the creative cylindrical surface along the direction of rolling (Fig. 3). It indicates not only the development of macrodamage during mechanical loading of samples far outside the zone of necking formation, but, perhaps, distorts the results of mechanical tests, especially in relation to plasticity characteristics. The similar type of distortion of mechanical tests results are characteristic for operational degradation of steels for operational steels degradation by the mechanism of damage development [15–17].

Conclusions. On the example of the investigations of metal state of «Sokil» brand portal crane after 33 years of operation, the regularities of degradation of rolled low-carbon

steels of over normative exploited structures of port transshipment equipment are summarized. The main mechanism of steel degradation under cyclic loading is the development of micro-damage along the rolling direction, therefore Charpy *KCV* impact strength tests, as characteristics of resistance to brittle fracture, are proved to be effective in assessing the metal state. In this connection, preference should be given to the samples transverse to the direction of rolling. On the one hand, there is the correlation between the experimental *KCV* values and, on the other hand, the level of cyclic stress σ_e obtained by calculation-tensometric method, the impact strength is lower for higher σ_e values. This is the substantiation of the fact that despite the responsibility of cyclic loading for the operational metal degradation, it is possible to use for its assessment not the fatigue strength characteristics, but the resistance to brittle fracture. On the other hand, the determined regularity of more intensive degradation of metal with smaller thickness permits the manifestation of aggressive role of marine environment not only for the corrosion intensification, but also in hydrogenating of the metal in its volume. Under such conditions, the development of micro-damage increases, including by the mechanism of micro-delamination in the rolling direction of the rolled product, which is indicated by sharp decrease in KCV_c / KCV_l ratio.

References

1. Iegupov K., Rudenko S., Nemchuk O. Safety and development of marine transportation-technological systems. *Industrial Machine Building: Civil Engineering*. 2018. Vol. 51. Iss. 2. P. 45–49. <https://doi.org/10.26906/znp.2018.51.1291>
2. Zrnic N. D., Bosnjak S. M., Gasic V. M., Arsic M. A., Petkovic Z. D. Failure analysis of the tower crane counterjib. *Procedia Eng.* 2011. Vol. 10. P. 2238–2243. <https://doi.org/10.1016/j.proeng.2011.04.370>
3. Nemchuk O. O., Nesterov O. A. In-service brittle fracture resistance degradation of steel in a ship-to-shore portal crane. *Strength of Materials*. 2020. Vol. 52. No. 2. P. 275–280. <https://doi.org/10.1007/s11223-020-00175-w>
4. Semenov P. O., Pustovyi V. M. Complex diagnostics of the state of operated elements of a grab reloader. *Mat. Sci.* 2020. Vol. 56. No. 2. P. 181–186. <https://doi.org/10.1007/s11003-020-00413-1>
5. Pustovyi V. M., Semenov P. O., Nemchuk O. O., Hredil M. I., Nesterov O. A., Strelbitskyi V. V. Degradation of Steels of the Reloading Equipment Operating Beyond Its Designed Service Life. *Materials Science*. 2022. Vol. 57. P. 640–648. <https://doi.org/10.1007/s11003-022-00590-1>
6. Li-xin Ren, Jian-qiang Ma, Yao-ting Tong, Zheng-qiu Huang. A review of fatigue life prediction method for portal crane. *IOP Conference Series: Earth and Environmental Science*. 2021. Vol. 657. 012094. Doi: 10.1088/1755-1315/657/1/012094. <https://doi.org/10.1088/1755-1315/657/1/012094>
7. Zvirko O. I. Electrochemical methods for the evaluation of the degradation of structural steels intended for long-term operation. *Materials Science*. 2017. Vol. 52. No. 4. P. 588–594. <https://doi.org/10.1007/s11003-017-9994-9>
8. Nemchuk O. O. Influence of the working loads on the corrosion resistance of steel of a marine harbor crane. *Materials Science*. 2019. Vol. 54. No. 5. P. 743–747. <https://doi.org/10.1007/s11003-019-00241-y>
9. Krasowsky A. Y., Dolgiy A. A., and Torop V. M. Charpy testing to estimate pipeline steel degradation after 30 years of operation. *Proc. “Charpy Centary Conference”, Poitiers*. 2001. Vol. 1. P. 489–495.
10. Nemchuk O. O., Krechkovska H. V. Fractographic substantiation of the loss of resistance to brittle fracture of steel after operation in the marine gantry crane elements. *Metallofiz. Noveishie Tekhnol.* 2019. Vol. 41. P. 825–836. <https://doi.org/10.15407/mfint.41.06.0825>
11. Krechkovska H. V., Student O. Z. Determination of the degree of degradation of steels of steam pipelines according to their impact toughness on specimens with different geometries of notches. *Materials Science*. 2017. Vol. 52. No. 4. P. 566–571. <https://doi.org/10.1007/s11003-017-9991-z>
12. T. Tsuru, Ya. Huang, Md. R. Ali, A. Nishikata Hydrogen entry into steel during atmospheric corrosion process. *Corr. Sci.* 2005. Vol. 47. No. 10. P. 2431–2440. <https://doi.org/10.1016/j.corsci.2004.10.006>
13. Omura T., Kudo T., Fujimoto S. Environmental factors affecting hydrogen entry into high strength steel due to atmospheric corrosion. *Mat. Trans.* 2006. Vol. 47. No. 12. P. 2956–2962. <https://doi.org/10.2320/matertrans.47.2956>
14. Kittel J., Martin J.W., Cassagne T., Bosch C. Hydrogen induced cracking (HIC) – Laboratory testing assessment of low alloy steel linepipe. *Corrosion* 2008, Mar 2008, New-Orleans, United States. fhal-02475529. <https://doi.org/10.1016/j.prostr.2019.07.048>

15. Nemchuk O., Hredil M., Pustovoy V., Nesterov O. Role of in-service conditions in operational degradation of mechanical properties of portal cranes steel. *Procedia Structural Integrity*. 2019. Vol. 16. P. 245–251. <https://doi.org/10.3846/13923730.2014.971128>
16. Maruschak P., Danyliuk I., Prentkovskis O., Bishchak R., Pylypenko A., Sorochak A. Degradation of the main gas pipeline material and mechanisms of its fracture. *Journal of Civil Engineering and Management*. 2014. Vol. 20. Issue 6. P. 864–872. <https://doi.org/10.3390/ma14123247>
17. Nykyforchyn H., Zvirko O., Dzioba I., Krechkovska H., Hredil M., Tsyrunyk O., Student O., Lipiec S., Pala R. Pala Assessment of operational degradation of pipeline steels. *Materials*. 2021. Vol. 14. P. 3247.

УДК 621.875

МЕТОДИЧНІ ОСОБЛИВОСТІ ВИВЧЕННЯ ДЕГРАДАЦІЇ ВАЛЬЦЬОВАНИХ СТАЛЕЙ ПОРТАЛЬНИХ КРАНІВ

Олександр Нестеров

Одеський національний морський університет, Одеса, Україна

Резюме. Конструкційним сталям тривалої експлуатації властива деградація їх стану, яка проявляється у значному спаді вихідних механічних властивостей. Вальцьовані конструкційні сталі портових конструкцій, які експлуатуються в режимі інтенсивного циклічного навантаження, особливо вразливі до деградації їх механічних властивостей. До них відносять, у першу чергу, низьковуглецеві сталі перевантажувальних машин, зокрема порталних кранів. Основу дослідження склали випробування на ударну в'язкість зразків Шарпі сталі марки St-38b-2, вітчизняний аналог-сталь Ст. Зсп, порталного крана марки «Сокіл» після 33 років його експлуатації. Наведено значення ударної в'язкості поздовжніх і поперечних зразків стосовно напрямку вальцювання листового прокату для 10 локальних ділянок на різних конструкційних вузлах порталного крана. Для цих же ділянок розрахунково-тензометричним методом прогнозовано рівень циклічної напруженості на поверхні листового прокату. Існує кореляція між, з одного боку, експериментальними значеннями ударної в'язкості, з іншого, – рівнем циклічної напруженості: ударна в'язкість нижча для вищих значень напруженості. На цій основі проаналізовано переваги вивчення експлуатаційної деградації сталей на основі не характеристик втомної міцності, а характеристик опору крихкому руйнуванню. Значною мірою це зумовлено мікророзширенням уздовж витягнутих волокон у напрямі вальцювання прокату як основного механізму експлуатаційної деградації металу. Відповідно механічні властивості металу стають особливо чутливі до напрямку вирізування зразків стосовно напрямку вальцювання. Тому для оцінювання експлуатаційної деградації сталей рекомендовано використовувати поперечні зразки, в яких напрям мікророзширення збігається з напрямом вальцювання. Розглянуто також можливу роль морського середовища у посиленні деградації сталі через його наводнювальні властивості. За таких умов інтенсифікується розвиток пошкодженості, в тому числі за механізмом мікророзширення саме у напрямі вальцювання прокату. Допускається також, що водневий механізм впливу морського корозивного середовища реалізовується через утворення високих тисків водню в експлуатаційних дефектах.

Ключові слова: вальцьована сталь порталного крана, експлуатаційна деградація, опір крихкому руйнуванню, розширення.

https://doi.org/10.33108/visnyk_tntu2023.01.066

Отримано 26.01.2023