



UDC 621.311.8

DEVELOPMENT OF AN EDUCATIONAL LABORATORY STAND AT THE BASE FAST-ACTING AUTOMATIC RESERVE INPUT

**Bogdan Orobchuk; Serhii Babiuk; Oleh Buniak; Ivan Sysak; Liubov Kostyk
Myroslav Nakonechniy; Yaroslav Filiuk**

Ternopil Ivan Puluj National Technical University, Ternopil, Ukraine

Summary. Currently, the issue of improving the reliability and quality of power supply is one of the most important directions in the development of the electric power industry. Reducing material losses associated with short-circuits and reductions in power supply voltage in the power supply systems of critical industries facilities is of particular importance to the implementation of fast-acting automatic reserve input using a modern elemental base. The article considers the description and development of a demonstration laboratory stand of fast-acting automatic input of backup power in order to provide practical study and understanding of multilateral power supply so as to ensure the reliability of electricity supply to consumers.

Key words: automatic reserve input, automatic control, laboratory stand, load switch, microprocessor control system, software.

https://doi.org/10.33108/visnyk_tntu2023.04.012

Received 27.09.2023

Statement of the problem. One of the important requirements for modern power supply systems is to ensure stable and uninterrupted power supply to critical loads in case of power outages, which are steadily increasing [1]. This includes various security systems, medical equipment, communication and data processing systems, and many continuous technological processes. Usually, power outages in such systems cause economic losses, including downtime and failure of technological equipment, loss of information, interruption of communication systems, Internet sites, etc. In some cases, a power outage can affect the safety of life, technical security systems, emergency lighting and other important aspects. When using high-quality electrical equipment from well-known manufacturers, eliminating errors in the design of electrical facilities and their proper operation can usually significantly improve the reliability of power supply. For this purpose, it is necessary to redundantly backup power transmission channels to ensure uninterrupted power supply to critical loads using automatic transfer switches (ATS). They are designed to automatically switch power from the main source to the backup source when the main input voltage completely disappears or when the main source voltage parameters deviate from the normal range. This equipment is quite complex both in maintenance and operation, so training of qualified specialists should be carried out during the educational process on specially designed laboratory stands [2, 3].

Analysis of available research results. At present, there are sufficient number of schemes and variants of automatic redundancy implementation, but in educational institutions, laboratory stands characterizing ATS are built on outdated equipment in terms of technical performance. Therefore, the development of a new scheme for the implementation of automatic transfer switching on modern microprocessor equipment is of great relevance.

An analytical review of the known ATS schemes was carried out and options for organizing the automatic switching on of backup power were considered to identify the drawbacks and advantages of the latter. All automatic backup power supply schemes are divided into:

– a scheme with two independent inputs and combined at the output into one load circuit. Only one of the power inputs is connected in normal operation and emergency mode;

– a circuit with two independent inputs and two independent outputs for connecting the power supply, which are connected at the output by a sectional switch. In normal operation, both power inputs are connected, in emergency mode – only one [4, 5].

The training and adjustment circuit board considered in [6] is designed for modeling and debugging various devices based on AVR controllers. It can be used both to master the basics of microprocessor technology and to implement a large number of digital data processing tasks and control various peripheral devices. The disadvantages include the limited use of software when connecting peripheral equipment.

In [7], an approach to the development of a virtual analogue of the EV8031/AVR training and laboratory stand in the Proteus software environment is proposed. This approach allows students to gain practical skills in the development and creation of both hardware and software parts of microprocessor systems. The drawbacks of the stand include the use of 'ideal' elements, which affects its operation. In particular, it is necessary to correct time delays for the proper operation of the programme on a real stand.

The patent [8] describes the use of the 8-bit AVR microcontroller Atme-ga16/32, which has 16/32 KB of programmable Flash memory that provides up to 1000 erase/write cycles. The microcontroller has 32 programmable I/O lines and supports the JTAG interface. The test stand is powered from any source with a voltage of 13 V to 40 V using a diode bridge at the input and linear stabilisers L7805 and L7812. The test stand also employs the FT232R controller for connection to a personal computer via the RS232 interface. The disadvantages include the difficulty of applying it in the educational process, as it is necessary to study programming using this device.

Objective of the research. The purpose of developing this stand is to integrate advanced equipment and practical training in the educational process of uninterruptible power supply to consumers. This is due to the active development of information technology, in line with which higher education institutions need to participate in solving an important task – training of highly qualified specialists able to actively integrate into the technological process of society development [9]. At present, the demand for specialists who can perform their tasks efficiently in industries with a developed informatized and automated structure has increased significantly. Here it is also necessary to note the insufficient level of practical training of graduates to the production environment during the educational process [10].

Formulation of the problem. Today, quite a few options for line redundancy are used, among which the main schemes for organizing the automatic introduction of backup power can be distinguished.

1. Circuit of an automatic transfer switch with a source (line or transformer) located in the reserve and consists of two independent power sources 1 and 2. In normal mode, source 1 is used, in case of its failure, the magnetic starter PM1 is turned off and PM2 is turned on and the voltage on the power buses is restored (Fig. 1).

2. ATS circuit with a generator in reserve. The generator G is used as a backup source in the circuit. In case of a power failure from the main network, the ATS device automatically starts the generator G and disconnects the magnetic starter PM1, and after the generator G reaches the operating mode, it turns on the magnetic starter PM2 (Fig. 2).

3. ATS circuit with sectionalization (Fig. 3). Both sources (BFI 1 and BFI 2) operate simultaneously when the sectionalizer QF3 is off. In case of failure of one of the sources, the input circuit breaker of the failed source is disconnected and the sectionalizer QF3 is switched on.

4. A scheme of high-speed automatic transfer switches (Fig. 4). Microprocessor devices based on high-speed ATS are one of the main elements of designing a system of guaranteed power supply to the first category consumers. These devices allow to quickly record the fact of power supply failure, determine its nature and provide control influences on switchgear. The

use of high-speed automatic transfer switches together with specialized high-speed input and sectional switches allows to reduce economic losses from power supply failure by maintaining the continuity of the technological process and reducing the risk of emergencies caused by a possible unacceptable decrease in productivity or complete shutdown of critical mechanisms by reducing the time of switching to a backup power supply.

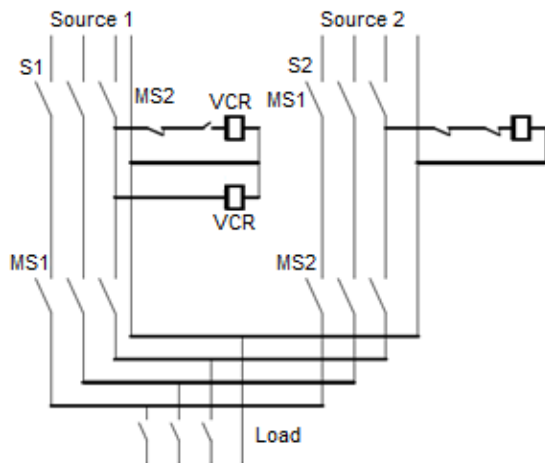

Figure 1. ATS circuit with two sources

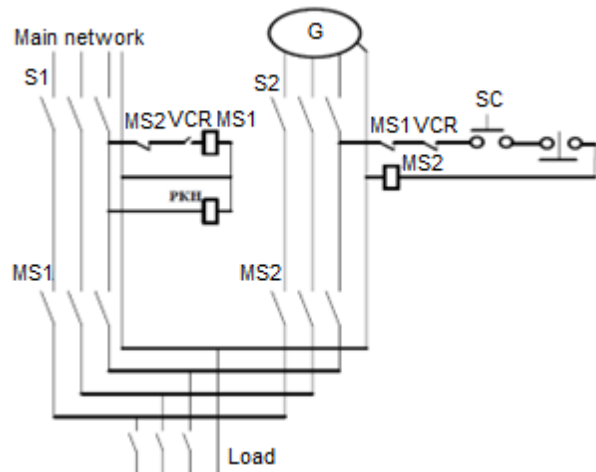

Figure 2. ATS circuit with a standby generator

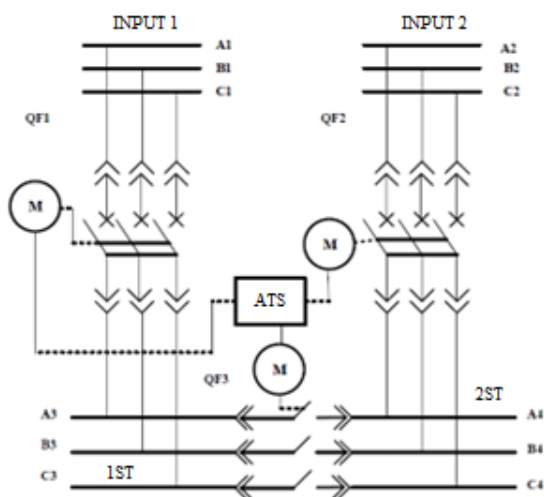

Figure 3. ATS circuit with sectionalisation

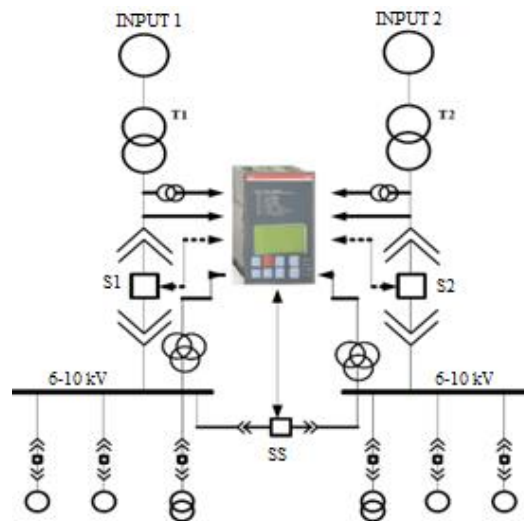

Figure 4. Circuit with a high-speed ATS

In the premises of the laboratory «Power Supply Management Systems» of the Electrical Engineering Department of Ivan Puluj Ternopil National Technical University, a laboratory stand with a high-speed ATS based on the control unit of automatic reversing switching equipment OMD800 from ABB with two power supplies was implemented. The elements of the ATS unit are placed in the test stand case. Fig. 5 shows a schematic electrical diagram of the laboratory stand.

Structure of the developed laboratory training stand. The laboratory training simulator was developed and implemented to visually study the operation of circuit breakers during testing of the ATS circuit by interactively studying the function of switching from the main power line to the backup and vice versa, from the backup to the main, as well as to improve students' practical skills in the educational process [11]. Switching devices provide for the possibility of installing a mechanical blockage.

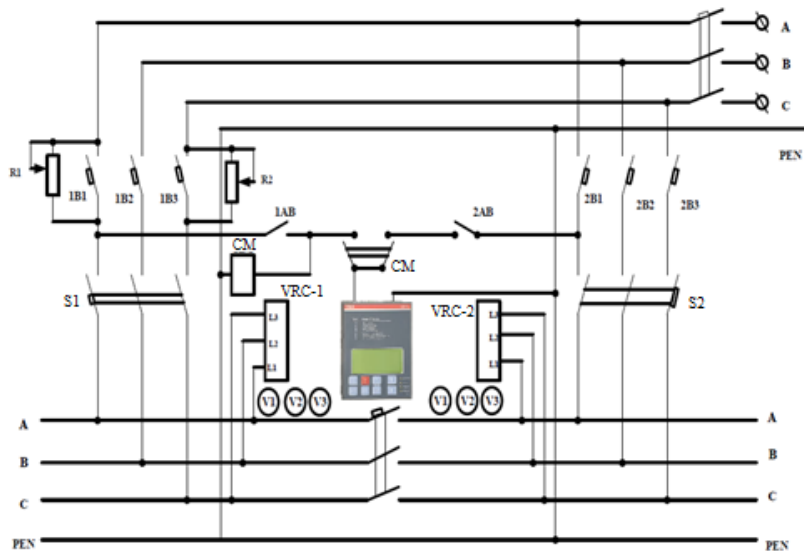

Figure 5. Circuit with a microprocessor-based high-speed ATS

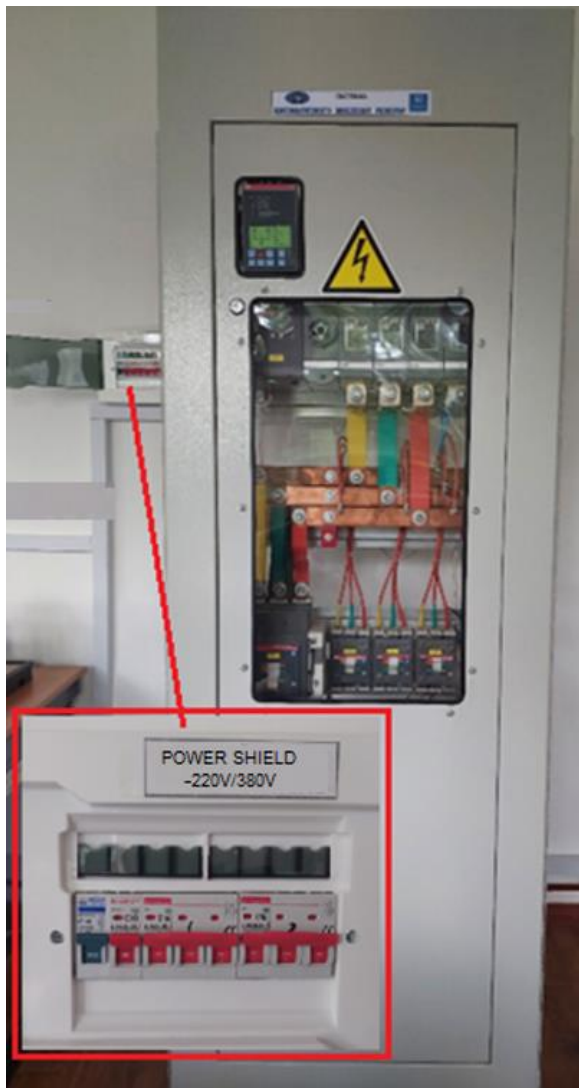

Figure 6. Laboratory stand of fast-acting ABP

The maximum current consumption of the laboratory simulator, which operates from an alternating current network of industrial frequency of 50 Hz with an effective voltage of 380 V, is 16 A (Fig. 6). The power lines are connected to 16 A three-pole circuit breakers, which are installed in the power panel on the left side of the laboratory stand (Fig. 6). The laboratory test facility is made in the form of a 0.4 kV cell cabinet. The power cabinet of the laboratory stand contains real samples of a reversing load breaker with a motor-drive, power circuit breakers, a load breaker, and an automatic control unit based on a microprocessor manufactured by ABB. Fig. 7 shows the installation of the load circuit breaker and power circuit breakers to which actuators can be connected during laboratory work.

A 630 A circuit breaker of the Tmax T5 series in a molded case with a rolling mode of operation is used as a load breaker [12]. The circuit breaker is controlled both manually and with the help of a motor drive and has a breaking capacity of 70 kA at 415 V AC. The circuit breaker has a 3-pole design for currents from 320A to 630A. The Tmax T5 is equipped with the PR221DS-LS electronic disconnecter (L – overload protection, S – short-circuit protection with time delay). The circuit breaker of this series provides zone selectivity,

can operate in motor protection circuits or be used as a disconnecter. It is not subject to vibrations caused by mechanical or electromagnetic influences. Increased isolation distances ensure the absence of leakage currents and reliable isolation at high overvoltages between the input and output. The design provides double insulation between the live power parts (terminals) and the front of the device.



Figure 7. Load-breaker and circuit breakers to consumers



Figure 8. Reversing load switch with motor drive and automatic control unit

Three circuit breakers of the Tmax T2 series were used as power circuit breakers for connecting actuators and conditional consumers during laboratory work. This circuit breaker is capable of providing a breaking capacity of 85 kA (Fig. 7). The circuit breaker has a 3-pole design for currents from 16 A to 160 A and is equipped with an electronic release [13]. The circuit breaker of the T2 series can be controlled both manually and by means of an electromagnetic drive. The circuit breaker can be included in the electric motor protection circuits – appropriate accessories are installed in the power cabinet.

As a reversing load breaker in the laboratory stand, we used a 34OTM_C/1SCC303002M9703 series circuit breaker with a motor drive manufactured by ABB, which consists of a reversing load breaker and a motor drive (Fig. 8). The reversing load switch with an electric motor is designed for remote control [14]. This makes it possible to operate it both remotely with the help of a motor drive and manually using the handle. The type of operation (remote or manual) is selected using the "AUTO/MANUAL" switch on the motor panel.

In the laboratory stand, an automatic control unit OMD800 on a microprocessor basis manufactured by ABB was used to implement the scheme of high-speed automatic introduction of the reserve (Fig. 9). It should be noted that the concept of automatic switching to the backup power supply line is used in all cases when it is necessary to switch it from the main power supply line to the backup one in order to maintain the voltage at the load [15].

The OMD800 unit contains two sensors that monitor the operational status of two power lines and can work with both single-phase and three-phase voltage lines [16]. Monitoring, configuration, and control are carried out using the Modbus RTU protocol. The OMD800 unit is equipped with a graphic display for checking technical parameters and obtaining the necessary information about its status. In case of a voltage loss in the main power line I, the OMD800 unit switches to the backup emergency power line II (Fig. 10).

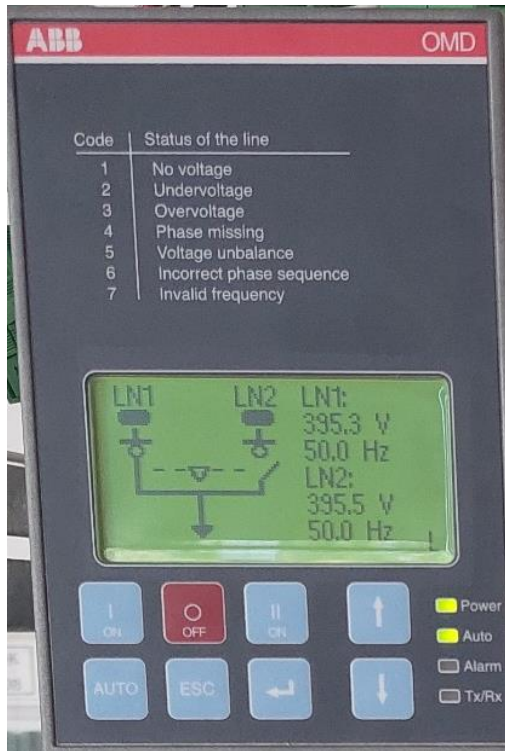

Figure 9. OMD800 automatic control unit

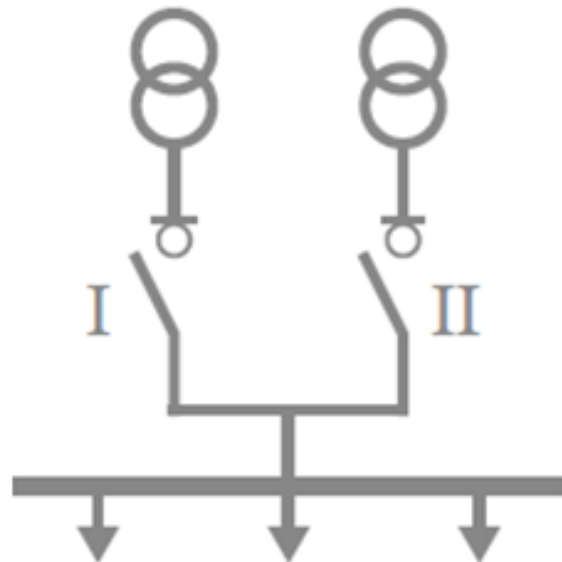

Figure 10. Main network I and backup network II

The OMD800 automatic control unit is mounted on the mounting bus of the load-reversing circuit breaker (Fig. 8). In order to ensure safe conditions during laboratory work, a rectangular hole was cut out on the door of the power cabinet to the size of the front panel of the OMD800 automatic unit (Fig. 6).

Functional features of the stand:

1. Adjustment of the output voltage at INPUT 1 in the range from 100 to 400 V.
2. Ability to simulate skew or loss of voltage on both inputs.
3. Allows to supply a current from 0 to 10 A to test the operation of the current protection.
4. Can simulate the stand operation in automatic or manual mode.

Integration of the developed laboratory stand into a training system of dispatch control. It is worth noting that automatic backup is a system for maintaining power supply to devices and consumers that are critical to short-term or long-term power outages. This system is used in cases where it is necessary to switch the load between independent sources of electricity when an emergency occurs or any other failure in the power supply system occurs. At present, contactor-based ATS schemes with an automatic circuit breaker and a motor drive are widespread.

When designing the laboratory stand, a geared motor scheme was preferred, since the switch is the fundamental element of this system and the switching between the middle and zero positions is performed by a motor drive. The drive is operated by a controller, which is installed separately next to the switch. The developed scheme uses a full-function relay, which monitors the voltage and frequency in each of the three phases, and provides the ability to program the delay and response range. The advantage of such relays is full control of the power supply network parameters. In case of a malfunction, the controller or actuator can be replaced immediately without dismantling the circuit breaker and the ATS panel itself. In this case, it is possible to switch the load in manual mode (using the handle) with the controller and drive removed.

The OMD800 automatic control unit also controls phase sequencing. It is equipped with a graphic display, has a Modbus RTU data transfer interface, and configurable discrete inputs and outputs. The display shows the unit status in the form of a mnemonic diagram and the main parameters (Fig. 9). Using the display and the front panel buttons, all the necessary settings and view diagnostic information using the menu can be performed. The data transmission interface allows you to remotely receive information about the ATS status, adjust the operating parameters and send control commands. This makes it possible to include ATS with OMD800 control units in monitoring and dispatching systems.

Therefore, there was a decision to integrate the developed laboratory stand into the training SCADA-system «Energy» of the software and hardware complex «Arrow» [17]. This system is a stand of an automated supervisory control system for studying and controlling the modes of electric power systems [9–11]. The stand is a hardware and software complex and is used in the education and training process to practice emergency training exercises with the reflection of the operational situation in the power system. The stand allows to model the modes of operation of the power grid during practical classes, as well as to connect various actuators and equipment and control them remotely. The developed laboratory stand on the basis of high-speed automatic reserve input, together with the developed software, will become a part of the laboratory complex for constructing telecontrol and dispatch control systems in the electric power industry [18].

When developing the software for connecting the developed laboratory test stand to the educational SCADA-system «Energy», line I was chosen as a priority (Fig. 10).

The sequence of operations performed by the OMD800 unit when switching lines is as follows:

- ✓ fault occurrence in line 1;
- ✓ switching delay;
- ✓ generator launch (if any);
- ✓ transmission delay;
- ✓ if the reserve prior activation signal is activated:
 - the reserve prior switch-on signal output is enabled,
 - reserve prior switch-on delay I-II;
- ✓ turning the reversing switch (Switch I) to the O (off) position;
- ✓ delay in the insensitive zone during the switch from line I to line II;
- ✓ switching of the reversing circuit breaker (Breaker II) to position II;
- ✓ if the reserve prior switching signal is activated:
 - the output of the reserve prior switching signal is turned off.

The sequence of steps to be performed during the reverse switchover is as follows:

- ✓ resume normal line operation 1;
- ✓ delay the reverse switching;
- ✓ if the reserve prior switching signal is activated:
 - the output of the reserve prior switching signal is on,
 - reserve prior switching delay II-I;
- ✓ moving the reversing switch (Switch II) to the O (off) position;
- ✓ delay in the insensitive zone during the transition from line I to line II;
- ✓ moving of the reversing switch (Breaker I) to position I;
- ✓ if the reserve pre-enablement signal is activated:
 - the output of the reserve prior switching signal is off;
- ✓ generator shutdown delay (if any);
- ✓ generator shutdown (if any).

The cyclogram of the above operations is shown in Fig. 11.\

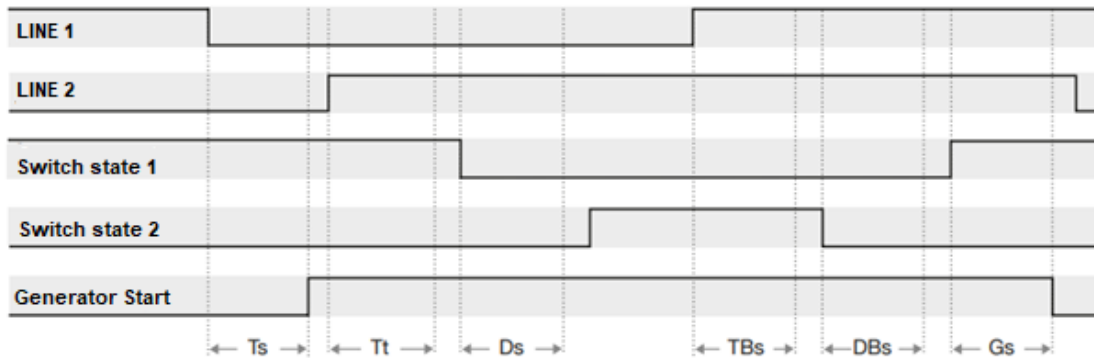

Figure 11. Sequence of automatic switching operations of OMD800:

Ts – switching delay, Tt – transmission delay, Ds – delay in the dead zone during the transition from line I to line II, TBs – reverse switching delay, DBs – delay in the dead zone during the transition from line II to line I, Gs – generator shutdown delay

In order for the hardware and software complex to exchange data with the controller of the OMD800 automatic control unit, it is necessary to develop an exchange program based on the Modbus RTU protocol [19]. The text below is a developed data exchange program based on this protocol, i.e., the Modbus RTU device map file, which contains the main commands from the available list that will be used by the Arrow hardware and software complex. Only a part of the available commands of the OMD800 block register is used here; if necessary, these commands can be added to the software of the developed laboratory stand.

Modbus RTU device card file

```
[GENERAL]
AddressDecrement=0
[REQWEST]
; Start address, number of registers, Modbus command, group 101, whether included in the
general protocol
reqwest01=58,14,3,1,1
reqwest02=150,15,3,1,1
reqwest03=166,11,3,1,1
reqwest04=250,3,3,1,1
[TVLIST]
; Start address, offset (for a bit), data type, scale (coefficient), start of scale
;Data types 0: ui16 1: i16 2: ui32 3: i32 4: float32
; 5: float48 6: Int64 7: float64 8: float80
; Start address, offset (for bit), data type, scale
1_U1 - phase A voltage of the first line (with an accuracy of 0.1 V)
tv001=150,0,1,0.1
;1_U2 – phase B voltage of the first line (with an accuracy of 0.1 V)
tv002=152,0,1,0.1
;1_U3 –phase C voltage of the first line (with an accuracy of 0.1 V)
tv003=154,0,1,0.1
;1_U12 – voltage between phases AB of the first line (with an accuracy of 0.1 V)
tv004=158,0,1,0.1
;1_U23 – voltage between phases BC of the first line (with an accuracy of 0.1 V)
tv005=160,0,1,0.1
```

;1_U31 – voltage between phases CA of the first line (with an accuracy of 0.1 V)
tv006=162,0,1,0.1
;2_U1 – phase A voltage of the second line (with an accuracy of 0.1 V)
tv007=164,0,1,0.1
;2_U2 – phase B voltage of the second line (with an accuracy of 0.1 V)
tv008=166,0,1,0.1
;2_U3 – phase C voltage of the second line (with an accuracy of 0.1 V)
tv009=168,0,1,0.1
;2_U12 - voltage between phases AB of the second line (with an accuracy of 0.1 V)
tv010=172,0,1,0.1
;2_U23 - voltage between phases BC of the second line (with an accuracy of 0.1 V)
tv011=174,0,1,0.1
;2_U31 - voltage between phases CA of the first line (with an accuracy of 0.1 V)
tv012=176,0,1,0.1
;1_F – frequency of the first power line (with an accuracy of 0.1 V)
tv013=250,0,1,0.1
;2_F – frequency of the second power line (with an accuracy of 0.1 V)
tv014=252,0,1,0.1
;Start address, offset (for a bit)
;Reg_SL_Status – Register of additional load status
tv015=60,0,0,1
;Reg_Generator_alarm – Generator failure signal register
tv016=61,0,0,1
;Reg_Force_manual – Register for forced switching to manual control mode
tv017=62,0,0,1
;Reg_Force_Comutation – Register of forced comutation
tv018=63,0,0,1
;Reg_Generator_start – Generator start register
tv019=64,0,0,1
;Reg_Inhibit_switching – Switching inhibit register
tv020=65,0,0,1
;Reg_Inhibit_remote – Remote control inhibit register
tv021=66,0,0,1
;Reg_Remote_O – Register for remote switching to position I
tv022=67,0,0,1
;Reg_Remote_1 – Register for remote switching to position I
tv023=68,15
;Reg_Remote_2 – Register for remote switching to position II
tv024=69,15
;Reg_Man_Back_Switching – Reverse switching register in manual mode
tv025=70,15
;Reg_Emergency_Stop – Emergency stop register
tv026=71,15
;Reg1_status – No-voltage register
tv027=58,0,0,1
;Reg2_status – Under-voltage register
tv028=59,0,0,1

[OK]
ok=ok

The developed program file of the Modbus RTU device map and the OMD800 automatic control unit itself are a real model of the training SCADA system «Energy». To integrate this model into the SCADA system environment, a graphical model (Fig. 12) and a configuration file containing the following data were created.

Configuration file

```
[GENERAL]
ObjectCount=1 – number of substations
ChannelsCount=1 – number of communication channels
DisableCrashLog=1 — disable the automatic creation of logs (by default, log data is
written to the Logs directory or the application startup directory)
CheckInterval=1000 – control checkup period in msec.
CommonRequestInterval=30000 — common request interval in msec.
; Modbus
[Channel1] - 1 communication channel is used
Type=1 - channel type (2 – TCP-IP, 1 – RS232)
Thread=1 – thread number
Port=7 – port number
Prm=19200-8-N-1 –RS232 connection parameters (19200 – frequency, 8 – 8 bits, N –
parity, 1 – stop bit)
ByteTimeOut=200 – waiting time for the next byte
DataReadTimeOut=3500
DeffaultTimeout=2000
Description=Modbus
[Object1]
Type=7
ModbusTCP=0 – The protocol used is not the classic Modbus TCP, but a specialised
Modbus RTU protocol is used
Address=42 – model address
Channel=1 – 1st communication channel
Paused=0 – survey delay time
// Modbus RTU map file name of the device
Map=ABB_OD800 – object model
Description=AVR(ABB) – model description
[MainForm] - parameters of the main window for viewing data exchange logs (filled in
automatically).
Top=179
Left=738
Width=890
Height=627
LVHeight=150
[ModelState] - parameters of the window for graphic diagram placement of the model
Top=17
Left=247
Width=887
Height=974
[LogForm0]
Top=182
Left=182
```

Width=698
 Height=316
 [LogForm1]
 Top=500
 Left=32
 Width=698
 Height=316

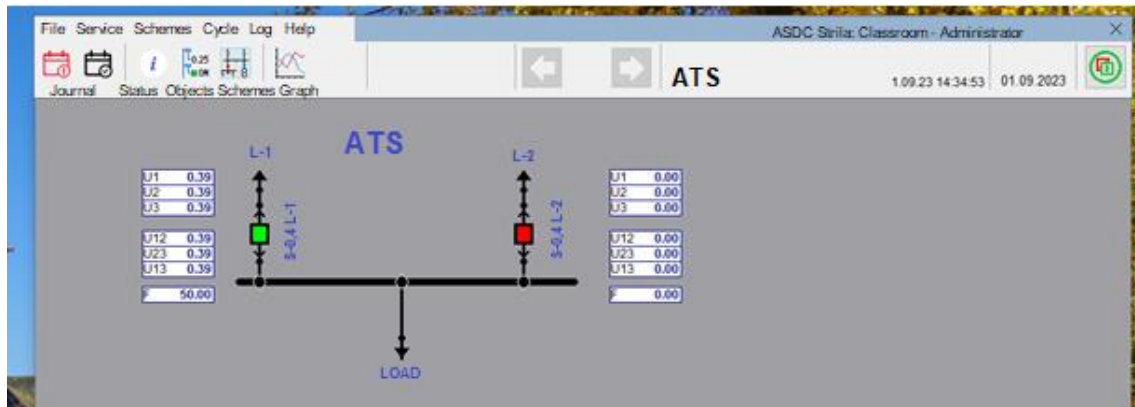

Figure 12. Window of the graphical model of a high-speed ATS

The program communicates with the equipment via a communication channel, which is an RS232-RS485 connection. Then the data is sent to the equipment model, where messages are processed. From the equipment model, the data is transferred to the real model, where the final processing is performed.

In the real model, the message is recorded in the database, analyzed for an emergency, and all information about the current state of the model is stored. During the work, the student uses a graphical model that requests data from the real model and displays it in a form familiar to the user – a mnemonic scheme (Fig. 12).

Conclusions. As a result of the development, we considered the possible use and implementation of a microprocessor-based system of high-speed automatic reserve input into the educational process and its integration into an automated dispatch control system for studying and controlling the modes of electric power systems.

During the implementation of this project, the following problems were solved:

- automatic switching on of the backup power supply in the presence of two independent sources of electricity was provided;
- control of the parameters of deviation from the established norms and voltage dips in the power supply system, i.e., the ATS operation was organized as a consumer protection;
- a mechanism for blocking the ATS in case of a short circuit to ground was implemented;
- integration of the developed laboratory stand into the training system of dispatch control with the development of appropriate software.

The laboratory workshop is currently under development.

It can be generally concluded that the use of a laboratory stand based on a high-speed automatic reserve input with microprocessor control and its integration into a training stand of an automated dispatch control system is an urgent task. The obtained results of this project should be used by students to master the curriculum in the areas of training specialists in modern power supply control systems, automated dispatch control systems and their application for

informatization of education in order to improve the quality of training of graduates of higher technical educational institutions.

In this regard, it is worth noting that even a high-speed microprocessor-based ATS cannot ensure the continuity of power supply. If the power receivers do not allow interruptions in the voltage supply, then an uninterruptible power supply must be used for a certain period of time to switch the ATS devices and start the generator. Its energy reserve should be sufficient to power the loads until the generator reaches the operating mode, which may take several minutes. Often, an uninterruptible power supply is designed for a longer period of time to power the load. In this case, the power supply system with an alternative generator and an uninterruptible power supply can be used continually.

The authors express their gratitude to the Ternopil Design Bureau of Radio Engineering «Strila», in particular to Director Oleksandr Rafaliuk and programmer Serhii Dudin, for their assistance in developing the laboratory stand and its software.

References

1. Burbelo M. Y., Biryukov O. O., Melnychuk L. M. *Systemy elektropostachannya. Elementy teorii ta pryklady rozrakhunkiv: navchalnyy posibnyk*. Vinnytsya: VNTU, 2011. 204 p. ISBN 978-966-641-450-5. [In Ukrainian].
2. Orobchuk B. Ya., Bunyak O. A. *Metodyka zastosuvannya systemy keruvannya rezhymamy elektropostachannya u navchalnomu protsesi. Materialy VII mizhnarodnoyi naukovo-tekhnichnoyi konferentsiyi "Pidvyshchennya rivnya efektyvnosti enerhospozhyvannya v elektrotekhnichnykh prystroyakh i systemakh"* (Lutsk, 23 chervnya 2018 r.), *M-vo osvity i nauky Ukrainy, Lutskyy natsion. tekhn. un-t [ta in]*. Lutsk: LNTU, 2018. P. 67–71. [In Ukrainian].
3. Orobchuk B. Ya. *Dilovi ihry v navchal'nomu protsesi v yakosti instrumenta profesiynoyi pidhotovky mahistriv. VI Mizhnarodna naukovo-tekhnichna konferentsiya "Svitlotekhnika y elektroenerhetyka: istoriya, problemy, perspektyvy"* (Ternopil – Yaremche, 30 sichnya – 2 lyutoho 2018 r.), *M-vo osvity i nauky Ukrainy, Tern. natsion. tekhn. un-t im. I. Pulyuya [ta in]*. Ternopil: TNTU, 2018. P. 95–96. [In Ukrainian].
4. Diponkar Paul, Md. Shariful Islam, Syed Khalid Rahman. Performance evaluation and operation of Auto Load transfer switch, *International Journal of Renewable and Sustainable Energy* 2013; 2 (6): P. 205–211. <https://doi.org/10.11648/j.ijrse.20130206.13>
5. ZHU Zefeng, ZHAO Jinquan, WEI Wenhui, LIN Changnian, YU Yiping. Optimal Charging and Discharging Scheme of Battery Energy Storage System in Active Distribution Network. *Journal: Automation of Electric Power Systems*. 2016. Issue 20. P. 47–54.
6. Diduk V. A. *Metodychni vkazivky do vykonannya laboratornykh robit z kursu "Mikroprotsesorna tekhnika" dlya studentiv napryamku pidhotovky 6.050202 "Avtomatyzatsiya ta kompyuterno-intehrovani tekhnolohiyi"*. Cherkasy, ChNU im. B. Khmelnytskoho, 2013. 56 p. [In Ukrainian].
7. Tsyrunyk S. M., Roptanov V. I. *Kompyuteryzovanyy laboratornyy virtualnyy stend. Visnyk Vinnytskoho politekhnichnoho instytutu*. 2010. Vol. 4. ISSN 1997-9266. [In Ukrainian].
8. Savchenko O. V., Bilyuk I. S., Fomenko A. M., Shareyko D. Yu., Havrylov S. O., Buhrim L. I., Kyrychenko O. S., Olshevskyy S. I., Fomenko L. A. Pat. 136572 *Ukrayina. Laboratornyy stend dlya prohrumuvannya mikrokontroleriv AVR*. Zayavl. 04.03.2019; opubl. 27.08.2019, *Byul. Vol 16*. [In Ukrainian].
9. Orobchuk B., Sysak I., Babiuk S., Rajba T., Karpinski M., Klos-Witkowska A., Szkarczyk R., Gancarczy J. Development of simulator automated dispatch control system for implementation in learning, 2017 9th IEEE International Conference on Intelligent Data Acquisition and Advanced Computing Systems: Technology and Applications (IDAACS). IEEE, Buharest. Vol. 1. September 2017. P. 210–214. <https://doi.org/10.1109/IDAACS.2017.8095078>
10. Orobchuk B. Ya., Piskun S. O., Rafalyuk O. O. *Vprovadzhennya system telemekhaniky keruvannya enerho-obyektamy v navchalnomu protsesi. III Vseukrayinska naukova-tekhnichna konferentsiya "Teoretychni ta prykladni aspekty radiotekhniki i pryladobuduvannya"* (Ternopil, cherven 2017 r.), *M-vo osvity i nauky Ukrainy, Tern. natsion. tekhn. un-t im. I. Pulyuya [ta in]*. Ternopil: TNTU, 2017. P. 224–226. [In Ukrainian].
11. Orobchuk B., Buniak O., Babiuk S., Sysak I. Design of an intelligent system to control educational laboratory equipment based on a hybrid mini-power plant. *Eastern-European Journal of Enterprise Technologies*. 2023. 2 (9–122). P. 59–72. (Scopus ISSN 1729-3774). <https://doi.org/10.15587/1729-4061.2023.277835>
12. *Vymykachi navantazhennya, Ofitsiyyny predstavnyk ABB v Ukraini [Veb-sayt]*. Kharkiv, 2023. URL: <https://abbua.com.ua/nizkovoltne-obladnannya/vimykachi-navantazhennya-abb>.

13. Sylovi avtomatychni vymykachi, Ofitsiynyy predstavnyk ABB v Ukraini [Veb-sayt]. Kharkiv, 2023. URL: <https://abbua.com.ua/nizkovoltne-obladnannya/silovi-avtomatichni-vimikachi>.
14. Reversivni vymykachi navantazhennya. Ofitsiynyy predstavnyk ABB v Ukraini [Veb-sayt]. Kharkiv, 2023. URL: <https://abbua.com.ua/nizkovoltne-obladnannya/vimikachi-navantazhennya-abb/reversivni-vimikachi-navantazhennya>.
15. Bazhenov V. M., Odehov M. M. Kharkiv Avtomatyka elektroustanovok elektroenerhetychnykh system: navchalnyy posibnyk. Planeta-Print, 2022. 186 p. [In Ukrainian].
16. Automatic control units, OMD800. Installation and operating instructions. ABB Oy, Protection and Connection. P.O. Box 622, FI-65101 Vaasa, Finland. URL: <http://new.abb.com/low-voltage>.
17. Avtomatyzovana systema dyspetcherskoho keruvannya "Strila". Tekhnichnyy opys i instruktsiya z ekspluatatsiyi. Ternopil, 2010. [In Ukrainian].
18. Orobchuk B. Ya. Laboratornyy kompleks dlya pobudovy system telekeruvannya i dyspetcherskoho upravlinnya v elektroenerhetytsi. Materialy XX naukovoyi konferentsiyi TNTU im. I. Pulyuya (Ternopil, traven 2017 r.), M-vo osvity i nauky Ukrainy, Tern. natsion. tekhn. un-t im. I. Pulyuya [ta in]. Ternopil: TNTU, 2017. P. 170–171. [In Ukrainian].
19. Modbus Technical Resources [Veb-sayt]. Andover, Massachusetts, SShA, 2023. URL: <https://modbus.org/tech.php> (data zvernennya: 15.08.2023)

Список використаних джерел

1. Бурбело М. Й., Бірюков О. О., Мельничук Л. М. Системи електропостачання. Елементи теорії та приклади розрахунків: навчальний посібник. Вінниця: ВНТУ, 2011. 204 с. ISBN 978-966-641-450-5.
2. Оробчук Б. Я., Буняк О. А. Методика застосування системи керування режимами електропостачання у навчальному процесі. «Підвищення рівня ефективності енергоспоживання в електротехнічних пристроях і системах»: матеріали VII Міжнар. наук.-техніч. конф. (м. Луцьк, 23 червня 2018 р.). Луцьк: ЛНТУ, 2018. С. 67–71
3. Оробчук Б. Я. Ділові ігри в навчальному процесі в якості інструмента професійної підготовки магістрів. «Світлотехніка й електроенергетика: історія, проблеми, перспективи»: VI Міжнар. наук.-техніч. конф. (Тернопіль–Яремче, 30 січня – 2 лютого 2018 р.). Тернопіль: ТНТУ, 2018. С. 95–96.
4. Diponkar Paul, Md. Shariful Islam, Syed Khalid Rahman. Performance evaluation and operation of Auto Load transfer switch. International Journal of Renewable and Sustainable Energy. 2013. 2 (6). P. 205–211. <https://doi.org/10.11648/j.ijrse.20130206.13>
5. Optimal Charging and Discharging Scheme of Battery Energy Storage System in Active Distribution Network / Author(s): ZHU Zefeng, ZHAO Jinquan, WEI Wenhui, LIN Changnian, YU Yiping, Journal: Automation of Electric Power Systems. 2016. Issue. 20. P. 47–54.
6. Дідук В. А. Методичні вказівки до виконання лабораторних робіт з курсу «Мікропроцесорна техніка» для студентів напрямку підготовки 6.050202 «Автоматизація та комп'ютерно-інтегровані технології». Черкаси, ЧНУ ім. Б. Хмельницького, 2013. 56 с.
7. Цирульник С. М., Роптанов В. І. Комп'ютеризований лабораторний віртуальний стенд. Вісник Вінницького політехнічного інституту. 2010. № 4. ISSN 1997-9266.
8. Україна. Лабораторний стенд для програмування мікроконтролерів AVR: пат. 136572 Україна; заявл. 04.03.2019; опубл. 27.08.2019, Бюл. № 16.
9. Orobchuk B., Sysak I., Babiuk S., Rajba T., Karpinski M., Klos-Witkowska A., Szkarczyk R., Gancarczy J. Development of simulator automated dispatch control system for implementation in learning process / 2017 9th IEEE International Conference on Intelligent Data Acquisition and Advanced Computing Systems: Technology and Applications (IDAACS). IEEE, Buharest. Vol. 1. September 2017. P. 210–214. <https://doi.org/10.1109/IDAACS.2017.8095078>
10. Оробчук Б. Я., Піскун С. О., Рафалюк О. О. Впровадження систем телемеханіки керування енергооб'єктами в навчальному процесі. «Теоретичні та прикладні аспекти радіотехніки і приладобудування»: III Всеукр. наук.-техніч. конф. (Тернопіль, червень 2017 р.). Тернопіль: ТНТУ, 2017. С. 224–226.
11. Orobchuk B., Buniak O., Babiuk S., Sysak I. Design of an intelligent system to control educational laboratory equipment based on a hybrid mini-power plant. Eastern-European. Journal of Enterprise Technologies. 2023. 2 (9–122). P. 59–72. (Scopus ISSN 1729-3774). <https://doi.org/10.15587/1729-4061.2023.277835>
12. Вимикачі навантаження. Офіційний представник ABB в Україні: веб-сайт. URL: <https://abbua.com.ua/nizkovoltne-obladnannya/vimikachi-navantazhennya-abb> (дата звернення: 05.08.2023).
13. Силові автоматичні вимикачі. Офіційний представник ABB в Україні: веб-сайт. URL: <https://abbua.com.ua/nizkovoltne-obladnannya/silovi-avtomatichni-vimikachi> (дата звернення: 05.08.2023).
14. Реверсивні вимикачі навантаження. Офіційний представник ABB в Україні: веб-сайт. URL: <https://abbua.com.ua/nizkovoltne-obladnannya/vimikachi-navantazhennya-abb/reversivni-vimikachi-navantazhennya> (дата звернення: 05.08.2023).

15. Баженов В. М., Одегов М. М. Автоматика электроустановок электроэнергетических систем: навчальний посібник. Харків: Планета-Прінт, 2022. 186 с.
16. Automatic control units, OMD800. Installation and operating instructions. ABB Oy, Protection and Connection. P.O. Box 622, FI-65101 Vaasa, Finland. URL: <http://new.abb.com/low-voltage>.
17. Автоматизована система диспетчерського керування «Стріла». Технічний опис і інструкція з експлуатації. Тернопіль, 2010.
18. Оробчук Б. Я. Лабораторний комплекс для побудови систем телекерування і диспетчерського управління в електроенергетиці: матеріали XX наукової конференції ТНТУ ім. І. Пулюя (Тернопіль, травень 2017 р.). Тернопіль: ТНТУ, 2017. С. 170–171.
19. Modbus Technical Resources: веб-сайт. URL: <https://modbus.org/tech.php> (дата звернення: 15.08.2023)

УДК 621.311.8

РОЗРОБЛЕННЯ НАВЧАЛЬНОГО ЛАБОРАТОРНОГО СТЕНДУ НА БАЗІ ШВИДКОДІЮЧОГО АВТОМАТИЧНОГО ВВЕДЕННЯ РЕЗЕРВУ

**Богдан Оробчук; Сергій Бабюк; Олег Буняк; Іван Сисак;
Любов Костик; Мирослав Наконечний; Ярослав Філюк**

*Тернопільський національний технічний університет імені Івана Пулюя,
Тернопіль, Україна*

Резюме. В даний час питання підвищення надійності та якості електропостачання є одними з найважливіших напрямків у розвитку електроенергетики. Для успішного вирішення цих завдань особливу увагу необхідно приділити проблемам розроблення та створення автоматичних високонадійних систем промислового електропостачання із забезпеченням безперебійного живлення. У роботі систем електропостачання виробництв критичних галузей промисловості можливі скидання навантаження, відключення та неполадки технологічних процесів при коротких замиканнях та помилкових відключеннях. Навіть короточасні зниження напруги зазначених виробництв, як правило, призводять до глибокого розладу технологічного процесу, значної матеріальної шкоди. Особливо важливу роль для зменшення матеріальних збитків, пов'язаних з короткими замиканнями та зниженнями напруги живлення в системах електропостачання підприємств критичних галузей промисловості відводиться впровадженню швидкодіючого автоматичного введення резерву із застосуванням сучасної елементної бази. Виконання вимог до створення досконаліших пристроїв швидкодіючого автоматичного введення резерву із застосуванням сучасної елементної бази викликає необхідність розроблення нових алгоритмів і принципів побудови таких пристроїв, які б забезпечували підвищення надійності роботи систем електропостачання підприємств критичних галузей промисловості. у статті розглянуто описування та розробка демонстраційного лабораторного стенду швидкодіючого автоматичного введення резервного живлення для можливості практичного вивчення та розуміння багатостороннього живлення з метою забезпечення надійності електропостачання споживачів. Варто зазначити, що розроблення промислового обладнання для вдосконалення навчального процесу в галузі електроенергетики з використанням найновіших технологічних досягнень є актуальним завданням. Такий підхід дозволяє практично вирішити питання закріплення отриманих теоретичних знань з базових дисциплін фахового профілю при підготовці майбутніх фахівців. Це є запорукою успішного працевлаштування та реалізації себе як спеціаліста в обраній галузі.

Ключові слова: автоматичне введення резерву, автоматичне керування, лабораторний стенд, вимикач навантаження, мікропроцесорна система керування, програмне забезпечення.

https://doi.org/10.33108/visnyk_tntu2023.04.012

Отримано 27.09.2023