



UDC 664.643

INFLUENCE OF ROLL CRUSHING OF PLANT MATERIAL ON THE CONSUMER CHARACTERISTICS OF «UKRAINSKE» BISCUITS

Ihor Stadnyk¹; Christina Kravchenyuk¹; Rostyslav Kravchenyuk¹;
Anna Sabadosh²

¹*Ternopil Ivan Puluj National Technical University, Ternopil, Ukraine*

²*Uzhhorod Institute of Trade and Economics of the Kyiv State University of Trade and Economics, Uzhhorod, Ukraine*

Summary. The study revealed that adding crushed flax seeds to the dough system prolonged the duration of its formation by 5 minutes. It was also noted that the amount of gluten in the dough was 17% less than in the control sample, which had a loose, unbound structure and lower extensibility. The impact of the rollers ensures a high-quality grinding process of flax seeds, which allows mucilage-forming polysaccharides to pass into the liquid phase of the dough and prevent the formation of a continuous gluten structure. It was also found that the necessary rheological properties are provided by adding 4–5% of crushed flax seeds to the dough recipe, while increasing the amount to 6% and above leads to a deterioration in organoleptic characteristics.

Key words: flax seeds «Vruchiy», gluten core, starch pasteurisation, flax seed polysaccharides, rheology, organoleptics.

https://doi.org/10.33108/visnyk_tntu2024.02.051

Received 17.01.2024

Statement of the problem. In many countries, as well as in Ukraine, the population is not sufficiently supplied with protein foods. Thus, the protein deficiency in the diet of the Ukrainian population is at least 25%. Protein and amino acid deficiency amid unfavourable environmental conditions has a negative impact on health, wellbeing and life expectancy of people. The lack of micronutrients and vitamins not only negatively affects the health, growth and development of the body, but also changes the kinetics of metabolism.

Effective processing of plant ingredients to preserve its chemical composition and vitamins requires a high-quality approach. Nowadays, crushing of raw materials with rolls is mainly determined by design and kinematic parameters. Among other things, rolls are subject to rather contradictory requirements in order to reduce unwanted heating of raw materials. It should be noted that the design parameters of the rolls should have minimal risks of raw material destruction, since in case of destruction, it becomes unusable by its composition and affects the quality of the product.

The consumption and production of confectionery products is consistently dominated by flour products, which include a wide range of biscuits. Biscuits are a high-calorie product, whose production technology is most favourable for creating health and nutritional baby food products based on it. Biscuits are thin, porous flour-based confectionery products of various shapes with low moisture content. The main raw materials for biscuits are flour, sugar, fat, egg and dairy products, flavouring agents and chemical leavening agents. There are three classes of biscuits: digestive, sugar, and butter.

Sugar biscuits are the most common type of bakery product. They are made from plastic dough with weak and medium gluten, sugar content of 20–30% and fat content of at least 9.5%. Sugar biscuits «Ukrainske» are particularly characterised by their crispness, porosity and swelling. It is a well-storable food concentrate and a highly digestible and high-calorie product.

It is known that processing of vegetable raw materials is necessary to add them to the recipe for products. Therefore, roll working bodies allow grinding raw materials to a high-quality condition (without changing the chemical composition of the ingredients). All of this draws attention of manufacturers to the efficiency of the equipment, as its operating parameters have a significant impact on both quality and quantity of biscuits produced.

Nowadays, rollers are widely used not only for grinding but also for kneading dough, especially in the process of dough formation, when it is enriched with non-traditional plant materials, biologically active additives and other functional ingredients. Such ingredients include oligosaccharides, dietary fibres, omega-3 fatty acids, phytochemicals (functional ingredients of plant origin), which have no energy value but support human health.

Currently, more than ever in a time of war, one of the most promising and effective ways to increase the biological value of products is to find and use plant-based raw materials. Flaxseeds can be such a raw material. Flaxseed is a highly nutritious source of protein, fat rich in unsaturated fatty acids, soluble and insoluble dietary fibre [1, 2, 3] and lignans [4, 5]. In addition, flaxseed is a source of lignans (aglycone phytoestrogens), which have antiviral, antioxidant, antibacterial, phytoestrogenic and oncoprotective properties. Human intestinal microflora converts plant lignans into two substances, enterolactone and enterodiol, known to be breast cancer protective agents [6, 7].

Analysis of recent research results. The use of different technological techniques and methods of dough preparation, as well as use of various types of plant raw materials, contributes to the improvement of organoleptic quality indicators of products [3, 6]. In the last decade, the range of so-called «craft» foods using starter products has significantly expanded [4, 8]. Due to unstable quality of raw materials, and in case of using non-traditional raw materials in the recipe as well as to prolong the freshness of biscuits, food additives-improvers are used, both individual components (enzymes, acidifiers) and complex improvers [9]. Scientists and enterprise staff are also working on the development of product recipes with non-traditional raw materials for biscuits to provide functional and health properties, increase nutritional value, and reduce energy value [9, 10].

One of the ways to improve the biscuits' nutritional value, including taste and aroma, is to use various types of additional raw materials [10]. In fact, it consists of cellulose, hemicelluloses, lignin, pectin, gums, mucilage and is a complex having the ability to bind environmentally harmful substances from the body, promote cation metabolism [11]. In recent years, many studies have been conducted to prove the importance of adding multifunctional additives from plant materials in the production of confectionery flour products as a source of functional ingredients (vitamins, dietary fibres, etc.).

The nutritional value of plant raw materials is determined by carbohydrates, vitamins, polyphenolic compounds, minerals, tannins, aromatic and other substances when processed and stored properly. The presence of functional ingredients in dough confectionery makes it possible to regulate and normalise the functions and biochemical reactions of the body. There are studies on the enrichment of dough with protein-lipid complexes after processing soybeans, carbohydrate-protein fractions of amaranth, legume seed flour, sunflower seeds, flax seeds, powdered products from vegetable and fruit extraction – provided that the machine parameters are reasonably influenced [11, 12]. To date, active searches are being conducted to improve the equipment and recipe composition of flour confectionery products, which will reduce their energy value and improve their protein, fatty acid, vitamin and mineral composition. For this purpose, products of flax seed processing can be used [13].

There is a lot of material in the literature on the use of cereal products [2, 6, 7, 9, 15]. However, little information is available on the use of flaxseed processing products in biscuits, which would enable us to conduct research in this area. For the most efficient use of the ground flaxseeds on the rolls, it is necessary to study the properties of the dough and its preparation, to

select the appropriate method of technological preparation in order to adjust the biscuit production process, which will ensure the production of high quality products. Thus, it is important to develop the technology of Ukrainian biscuits with increased nutritional and biological value using rollers for grinding flax seeds, the dosage of which will contribute to the balance of food rations and solve the problem of adequate protein nutrition. Yet, it should be noted that modern roll designs, in accordance with technological requirements, have intensive operating modes that significantly increase the numerical values of loads. The problem of searching and using new sources of natural raw materials and their high-quality processing in biscuit dough is relevant and viable.

Objectives of the research. The aim of the study is to investigate the introduction of ground flax seeds into the dough recipe under conditions of high-quality roll crushing and to investigate its effect on the physicochemical, structural and mechanical properties of the dough and organoleptic quality indicators of biscuits.

Substantiation of the results of the rolls influence by studying the physicochemical, structural, mechanical and organoleptic properties of the dough of «Ukrainske» biscuits when flaxseed processing products are added to the recipe. To determine the main quality indicators – moisture, acidity and ash content. Carry out an organoleptic evaluation of the manufactured samples according to the developed 5-point scale and construct a profilogram.

The main research results. The biscuit recipe includes first-grade wheat flour, water, fat, salt, sodium bicarbonate and egg products. The quality of biscuits is mainly shaped by the quality of the dough. When kneading the dough, flour is crucial, namely the amount of gluten and its quality (degree of stretchability, firmness and elasticity) [13]. The main protein fractions of gluten are glutenin and gliadin. The 'strength' of flour, a particularly important indicator in bakery production, is primarily characterised by its gluten elasticity and properties. The best results in biscuit production can be obtained by using low gluten flour, which has a favourable effect on the viscosity and distribution of the dough on the mould surface after the moulding machine. Biscuit dough has a low moisture content of up to 35%, as the consistency of the dough allows for a high-quality biscuit moulding process. Increasing the dough moisture content can lead to a reduction in oven productivity and an excess of outflows [15, 16]. In addition, the viscosity is affected by the dough temperature: higher than 25–30°C will increase its viscosity. Model experiments were conducted to determine the effect of ground flaxseed on the formation of biscuit «Ukrainske» dough from wheat flour [14]. Roller crushers (Fig. 1) are used for medium, thin and fine crushing of hard rocks, grinding of grain, vegetables, etc.

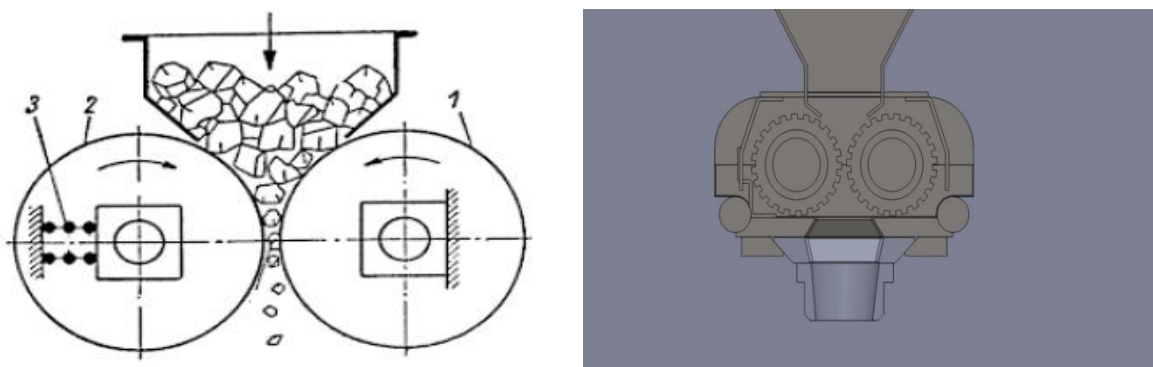

Figure 1. General diagram of a roll crusher: 1, 2 – rolls; 3 – spring and 3D model

The basic principle of flaxseed passing between moving rollers with a corrugated surface implies that it is pressed between these rollers and undergoes slight deformation, depending on the size of the particles and their textural characteristics. Therefore, the objects

6of the study were high-grade wheat flour (control) and a mixture of high-grade wheat flour and ground flax seeds in the amount of 4–5% by weight of flour (experimental sample), as well as dough made from them. Also, the object of the study was the crushed flax seed «Vruchiy» produced by Agrosilprom LLC, which was added to the biscuit recipe. The elastic and plastic characteristics of the dough were studied using a Brabender pharynograph (Germany) [17]. Quantity and quality of gluten in the control and experimental samples were evaluated according to standard methods [18].

The expert evaluation of biscuits is regulated by DSTU 3781:2014. «Biscuits. General technical conditions» according to the following indicators: mass fraction of moisture; mass fraction of fat; mass fraction of total sugar (in terms of sucrose); alkalinity; mass fraction of ash. Technological expertise is also carried out by determining organoleptic, microbiological indicators, and levels of permissible content of certain toxic elements and radionuclides [14, 19].

In this paper, the recipe of «Ukrainsky» biscuits was taken as a basis. The basic recipe included the following raw materials, in g (by weight/dry matter): high-grade wheat flour 100.0/85.5; egg yolk 10.0/4.6; table salt 0.5/0.483; sodium bicarbonate 0.5/0.25. In order to increase the nutritional and biological value and improve consumer properties, 1 to 5% (by dry matter content) of ground flax seeds was added to the recipe by reducing the amount of wheat flour. For this purpose, flax seeds produced by Agrosilprom LLC (TU U 15.8-24239651-007:2007) were used. This additive is a finely ground powder of light brown colour with a characteristic flax smell and taste. Flaxseed fibre can be recommended as an additional natural source of insoluble dietary fibre, amino acids, proteins, vitamins, macro- and microelements [16]. Fibre contains 34% protein, 14% fat, and 9% carbohydrates.

Fig. 2 shows a flowchart of studying of biscuit preparation. The moisture content of the crushed flaxseed sample was determined to be 8.75% and the ash content to be 5.1%.

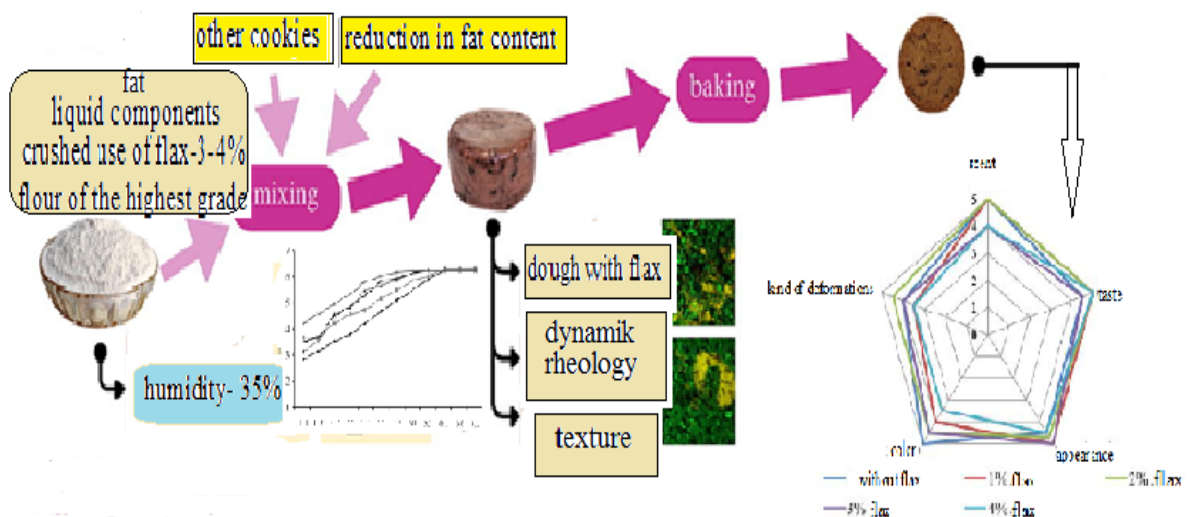

Figure 2. Flowchart of studying biscuit preparation

To determine the effect of the amount of crushed flaxseed on the dough density and the convenience of using this food additive in industrial production, the rheological parameters of the dough were measured using a rotational viscometer «Reotest-2» (Germany) with the construction of curves of the dependence of viscosity and stress on shear rate at different concentrations of crushed flaxseed. The results of the study are shown in Figs. 3 and 4.

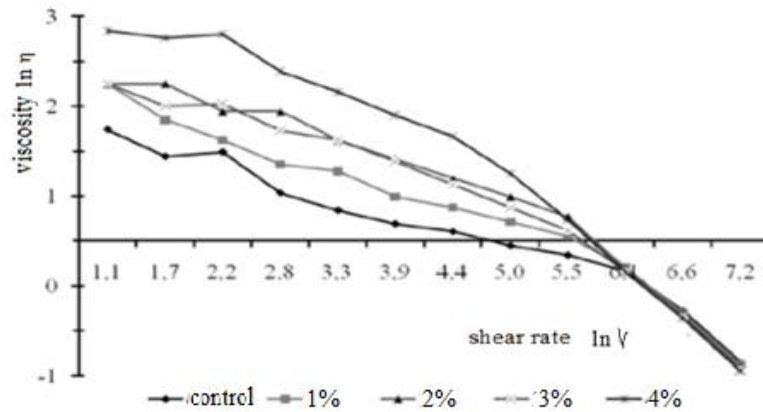

Figure 3. Changes in wafer dough viscosity with the addition of crushed flaxseeds

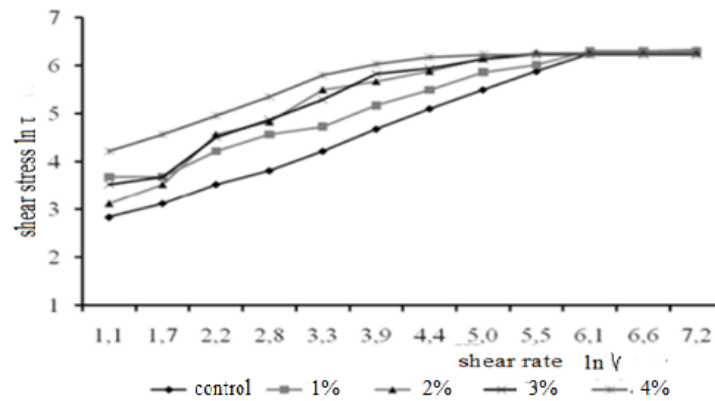

Figure 4. Change in the shear stress of the dough with the addition of crushed flax seeds

It was found that the introduction of crushed flaxseeds in the amount of 1–3% into the dough recipe increases the initial viscosity by 1.33–2.33 times compared to the control (dough without the addition of crushed flaxseeds). In addition, the structural properties are maintained as close as possible to the control sample. An increase in the dosage of crushed flaxseeds to 4% in the dough leads to a 4-fold increase in the initial viscosity and the shear stress required to destroy the system: from 17.1 Pa to 68 Pa. The consistency of the dough becomes more viscous, but retains its fluidity. With the addition of more than 4% crushed flaxseeds, the dough gradually loses its flowing consistency and becomes viscous, making it difficult to make and shape biscuits after the moulding machine. The use of 5% and 10% of crushed flaxseeds is not advisable, as the consistency of the dough becomes elastic, the time for homogenising the dough increases and its water absorption capacity increases.

Rheological properties of the dough with crushed flaxseeds have been studied and found to be optimal in terms of processability at a concentration of 2–4%, which allows to enrich the dough composition and increase its biological value, while maintaining the structural characteristics of the classic dough.

Based on the data obtained, a recipe for biscuits was developed, and they were produced and baked. Its organoleptic evaluation and determination of alkalinity, moisture and ash content were carried out. The dough dosage for each sample was ensured by

weighing it on an electronic scale, and the samples were baked in identical laboratory conditions with a predefined baking time.

The quality of the biscuits was assessed by such organoleptic parameters as shape, surface and colour, thickness and breaking surface look, smell and taste. The evaluation was carried out using a 5-point scale [20, 21]. Baked biscuit samples for organoleptic evaluation are shown in Fig. 5 and Table 1. The profile method is based on the fact that individual stimuli, when combined, give a qualitatively new sense of product taste. This method is the most convenient for assessing the quality of products with complex characteristics.



Figure 5. Biscuit samples: 1 – control; 2 – with 2% crushed flaxseeds; 3 – with 3% crushed flaxseeds

Table 1

Organoleptic evaluation of biscuits

<i>Indicator</i>	<i>Characteristics</i>
Shape	The shape of the product is regular, with smooth edges and uniform thickness
Surface	The surface is smooth, glossy, with a clear pattern, without pitting and cracks
Colour	Golden yellow, uniform. From light yellow to light brown
Look of breaking surface	Crispy. Evenly baked, with no traces of unleavened dough; homogeneous clearly visible porosity, few small voids
Taste and smell	Peculiar to biscuits, pleasant, distinct, with no foreign flavours

The developed system was used to construct the respective profilogram (Fig. 6).

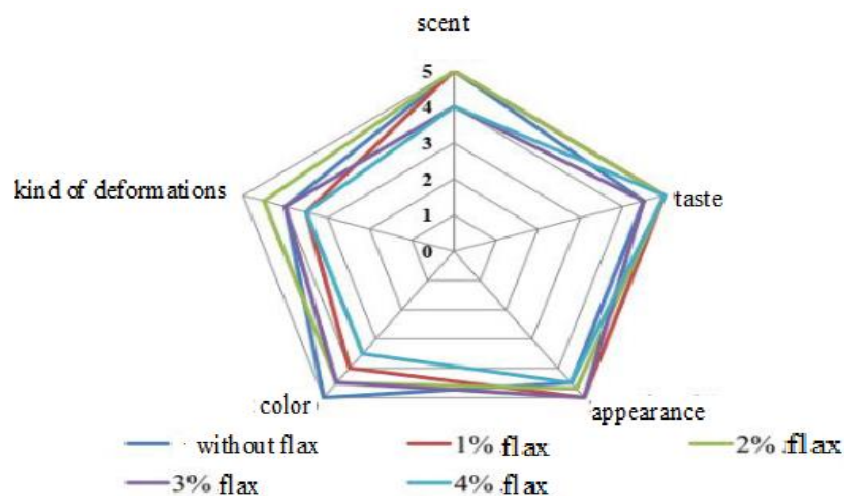

Figure 6. Profilogram of organoleptic biscuit quality assessment

The biscuits made by the developed recipe have pleasant taste and aroma, with a smooth cut and a clear surface, as well as developed porosity. As a result of the organoleptic evaluation of all the samples under study, the best of them (compared to the control sample) were biscuits with the addition of crushed flaxseeds in the amount of 2%, 3% and 4%.

In the present study, the physicochemical parameters of biscuits with different concentrations of crushed flaxseeds were determined: moisture content, alkalinity and ash content. It should be noted that the introduction of crushed flaxseeds increases the moisture content of the product. The moisture content of the new biscuits was slightly higher than the control ones, but within the established standards. Thus, the results of the research showed that the organoleptic and physicochemical parameters met the requirements set by the current standard without discrepancies.

Conclusions. Studies have shown that crushing flaxseed into particles up to 1.5 mm does not reduce its chemical composition. Rheological properties are provided by crushed seeds in the dough recipe in the amount of 2–3%. An increase in fine particles up to 4% and above leads to an increase in viscosity. The optimal use of crushed flax seeds in the amount of 1–3% allows you to enrich the composition of the dough and increase its biological value, while preserving the structural and organoleptic indicators characteristic of galettes. Using ground flaxseed does not change the baking time of the cookies.

The main quality indicators, such as moisture, alkalinity and ash content, were determined. The influence of rolls on the formation of flax particles was evaluated according to the developed 5-point scale and a profilogram was constructed. In this regard, in the production of cookies with the addition of crushed flax seeds, it is necessary to provide for an increased duration of kneading the dough. The use of ground flax seed additive does not affect the forming properties and baking time.

References

1. Makhinko V. M., Babich O. V., Makhynko L. V. Wild plants – a possible way to balance the food ration. Bakery and confectionery industry of Ukraine, 2011, no. 5, pp. 3–4.
2. Stadnyk I., Piddubnyy V., Chagaida A., Fedoriv V. (2022). Dynamics of interaction of components during mixing. Scientific Journal of TNTU, vol. 107, no. 3, pp. 86–98. https://doi.org/10.33108/visnyk_tntu2022.03.086
3. Novikova N. V. The use of non-traditional raw materials to improve the consumption properties of wafer-based cakes. Bulletin of the Kherson National Technical University, no. 2, 2020, pp. 48–54.
4. Shapoval S. L., Romanenko R. P., Forostyana N. P. Diagnostics of physical properties of food products: monograph. Kyiv: KNTEU, 2017. 192 p.
5. Stadnyk I., Piddubnyi V., Mykhailyshyn N., Petrychenko M., Fedoriv V., Kaspruk V. The influence of rheology and design of modelling rolls on the flow and specific gravity during dough rolling and injection. Journal of Advanced Manufacturing System, vol. 22, no. 01, pp. 35–48. <https://doi.org/10.1142/S0219686723500208>
6. Chemical composition of flax seeds. Available at: <https://dovidka.biz.ua/himichniy-sklad-nasinnya-lonu/> (accessed 05.22.2023).
7. Stadnyk I. Y., Piddubniy V. A., Krasnozhon S. V. Kraevska S. P. A scientific approach to the creation of food products with increased nutritional value. Modern engineering and innovative technologies, iss. 23, part 1, pp. 36–43.
8. Kraevska S. P., Piddubnyi V. A., Veselovska T. Ye., Stadnyk I. Ya., Bodnaruk O. A. Investigation of composition, properties and extraction parameters of flax seeds mucous-forming polysaccharides. Donetsk National University of Economics and Trade named after Mykhailo Tugan-baranovskyi. Scientific publication “Equipment and technologies of food production”. Thematic collection of scientific papers, no. 2 (43), 2021, pp. 71–79.
9. Simakova O. O., Nikiforov R. P. Development of the latest technologies of flour products with specified properties: monograph. Kryvyi Rih, DonNUET, 2018. 146 p.
10. Ivashkiv L. Ya. New classes of food ingredients and their functional properties. Nutritional problems, no. 3–4, 2010, pp. 61–66.
11. Stadnyk I., Piddubnyi V., Chahaida A., Fedoriv V., Hushtan T., Kraievskaya S., Kahanets-havrylko L., Okipnyi I. Energy saving thermal systems on the mobile platform of the mini-bakery. Contents of Journal of Mechanical Engineering. Strojnicky časopis, 2023, vol. 73, no. 1, pp. 169–186. <https://doi.org/10.2478/scjme-2023-0014>
12. Drobot V. I., Arsenyeva L. Yu., Bilyk O. A., etc. Laboratory workshop on the technology of bakery and pasta production: teaching. manual / under the editorship V. I. Drobot. K.: Center of educational literature, 2006, 341 p.
13. Drobot V. I., Izhevskaya O. P., Bondarenko Yu. V. Study of structural and mechanical properties of dough with flax meal. Bakery and confectionery industry of Ukraine, 2015, no. 10 (131), pp. 29–33.

14. Denysenko T. M. Commodity studies of flour confectionery products of increased biological value: autoref. thesis for obtaining sciences. candidate degree technical Sciences: spec. 05.18.15 “commodity science of food products” Kyiv, 2007, 24 p.
15. Syrokhman I. V., Zavhorodnia V. M. Commodity science of functional food products. Study guide. Kyiv, Center for Educational Literature, 2009, 544 p.
16. Iorgacheva K. G., Makarova O. V., Lukina G. D. Influence of the stage of introduction of flour from flax seeds on the quality of cookies, Collection, Science Pr. ONAKHT, Odesa, 2003, vol. 26, pp. 93–97.
17. Ildirova S. K., Stiborovskyi S. E., Staroste O. V. Technology of products from sand dough using wild spotted thistle, Food science and technology, 2010, no. 1 (10), pp. 91–94.
18. Lisovska T., Stadnik I., Piddubnyi V., Chorna N. Effect of extruded corn flour on the stabilization of biscuit dough for the production of gluten-free biscuit, Ukrainian food journal food engineering, vol. 9, issue 1, 2020, pp. 159–174. <https://doi.org/10.24263/2304-974X-2020-9-1-14>
19. Stadnyk I., Piddubnyy V., Ereemeeva O., Karpyk H. Features of heat transfer in the environment when it is sprayed with rotary rollers. Potravinarstvo Slovak Journal of Food Sciences, vol. 12, 2018, no. 1, pp. 824–835. <https://doi.org/10.5219/977>
20. Stadnyk I., Hushtan T., Sabadosh G., Yevchuk Ya. Formation of microbial biofilms on stainless steel with different surface roughness. Potravinarstvo Slovak Journal of Food Sciences, vol. 13, 2019, no. 1, pp. 915–924. <https://doi.org/10.5219/1190>
21. Stadnyk I., Piddubnyi V., Karpyk H., Kravchenko M., Hidzhelitskyi V. Adhesion effect on environment process injection. Potravinarstvo Slovak Journal of Food Sciences, vol. 13, 2019, no. 1, pp. 429–437. <https://doi.org/10.5219/1078>
22. Stadnyk I., Piddubnyi V., Chahaida A., Fedoriv V., Hushtan T., Kraievska S., Kahanets-havrylko L., Okipnyi I. Energy saving thermal systems on the mobile platform of the mini-bakery. Contents of Journal of Mechanical Engineering, Strojnícky časopis, 2023, vol. 73, no. 1. pp. 169–186. <https://doi.org/10.2478/scjme-2023-0014>

Список використаних джерел

1. Махинько В. М., Бабіч О. В., Махинько Л. В. Дикорослі рослини – можливий шлях збалансування харчового раціону. Хлібопекарська і кондитерська промисловість України. 2011. № 5. С. 3–4.
2. Stadnyk I., Piddubnyy V., Chagaida A., Fedoriv V. (2022). Dynamics of interaction of components during mixing. Scientific Journal of TNTU. Vol. 107. No. 3. P. 86–98. https://doi.org/10.33108/visnyk_tntu2022.03.086
3. Новікова Н. В. Використання нетрадиційної сировини для поліпшення споживних властивостей тортів на вафельній основі. Вісник Херсонського національного технічного університету. № 2. 2020. С. 48–54.
4. Шаповал С. Л., Романенко Р. П., Форостяна Н. П. Діагностика фізичних властивостей харчових продуктів: монографія. Київ : КНТЕУ, 2017. 192 с.
5. Stadnyk I., Piddubnyi V., Mykhailyshyn N., Petrychenko M., Fedoriv V., Kaspruk V. The influence of rheology and design of modelling rolls on the flow and specific gravity during dough rolling and injection. Journal of Advanced Manufacturing System. Vol. 22. No. 01. P. 35–48. <https://doi.org/10.1142/S0219686723500208>
6. Хімічний склад насіння льону. URL: <https://dovidka.biz.ua/himichnyi-sklad-nasinnya-lonu/> (дата звернення: 22.05.2023).
7. Stadnyk I. Y., Piddubnyi V. A., Krasnozhon S. V. Kraevska S. P. A scientific approach to the creation of food products with increased nutritional value. Modern engineering and innovative technologies. Iss. 23. Part 1. P. 36–43.
8. Kraevska S. P., Piddubnyi V. A., Veselovska T. Ye., Stadnyk I. Ya., Bodnaruk O. A. Investigation of composition, properties and extraction parameters of flax seeds mucous-forming polysaccharides. Donetsk National University of Economics and Trade named after Mykhailo Tugan-baranovskyi. Scientific publication «Equipment and technologies of food production». Thematic collection of scientific papers. No. 2 (43). 2021. P. 71–79.
9. Сімакова О. О., Никифоров Р. П. Розробка новітніх технологій виробів з борошна із заданими властивостями : монографія. Кривий Ріг : ДонНУЕТ, 2018. 146 с.
10. Івашків Л. Я. Нові класи інгредієнтів продуктів харчування та їхні функціональні властивості. Проблеми харчування. № 3–4. 2010. С. 61–66.
11. Stadnyk I., Piddubnyi V., Chahaida A., Fedoriv V., Hushtan T., Kraievska S., Kahanets-havrylko L., Okipnyi I. Energy saving thermal systems on the mobile platform of the mini-bakery. Contents of Journal of Mechanical Engineering. Strojnícky časopis. 2023. Vol. 73. No. 1. P. 169–186. <https://doi.org/10.2478/scjme-2023-0014>
12. Drobot V. I., Arsenyeva L. Yu., Bilyk O. A., etc. Laboratory workshop on the technology of bakery and pasta production: teaching. manual / under the editorship V. I. Drobot. K.: Center of educational literature, 2006. 341 p.
13. Drobot V. I., Izhevskaya O. P., Bondarenko Yu. V. Study of structural and mechanical properties of dough with flax meal. Bakery and confectionery industry of Ukraine. 2015. No. 10 (131). P. 29–33.
14. Denysenko T. M. Commodity studies of flour confectionery products of increased biological value: autoref. thesis for obtaining sciences. candidate degree technical Sciences: spec. 05.18.15 «commodity science of food products» Kyiv, 2007, 24 p.

15. Syrokhman I. V., Zavorodnia V. M. Commodity science of functional food products. Study guide. Kyiv, Center for Educational Literature, 2009. 544 p.
16. Iorgacheva K. G., Makarova O. V., Lukina G. D. Influence of the stage of introduction of flour from flax seeds on the quality of cookies, Collection, Science Pr. ONAKHT. Odesa. 2003. Vol. 26. P. 93–97.
17. Ildirova S. K., Stiborovskyi S. E., Staroste O. V. Technology of products from sand dough using wild spotted thistle, Food science and technology. 2010. No. 1 (10). P. 91–94.
18. Lisovska T., Stadnik I., Piddubnyi V., Chorna N. Effect of extruded corn flour on the stabilization of biscuit dough for the production of gluten-free biscuit, Ukrainian food journal food engineering. Vol. 9. Issue 1. 2020. P. 159–174. <https://doi.org/10.24263/2304-974X-2020-9-1-14>
19. Stadnyk I., Piddubny V., Eremeeva O., Karpyk H. Features of heat transfer in the environment when it is sprayed with rotary rollers. Potravinarstvo Slovak Journal of Food Sciences. Vol. 12. 2018. No. 1. P. 824–835. <https://doi.org/10.5219/977>
20. Stadnyk I., Hushtan T., Sabadosh G., Yevchuk Ya. Formation of microbial biofilms on stainless steel with different surface roughness. Potravinarstvo Slovak Journal of Food Sciences. Vol. 13. 2019. No. 1. P. 915–924. <https://doi.org/10.5219/1190>
21. Stadnyk I., Piddubnyi V., Karpyk H., Kravchenko M., Hidzhelitskyi V. Adhesion effect on environment process injection. Potravinarstvo Slovak Journal of Food Sciences. Vol. 13. 2019. No. 1. P. 429–437. <https://doi.org/10.5219/1078>
22. Stadnyk I., Piddubnyi V., Chahaida A., Fedoriv V., Hushtan T., Kraievska S., Kahanets-havrylko L., Okipnyi I. Energy saving thermal systems on the mobile platform of the mini-bakery. Contents of Journal of Mechanical Engineering. Strojnický časopis. 2023. Vol. 73. No. 1. P. 169–186. <https://doi.org/10.2478/scjme-2023-0014>

УДК 664.643

ВПЛИВ ВАЛКОВОГО ДРОБЛЕННЯ РОСЛИННОЇ СИРОВИНИ НА СПОЖИВЧІ ВЛАСТИВОСТІ ПЕЧИВА «УКРАЇНСЬКЕ»

Ігор Стадник¹; Христина Кравченко¹; Ростислав Кравченко¹;
Ганна Сабадош²

¹Тернопільський національний технічний університет імені Івана Пулюя,
Тернопіль, Україна

²Ужгородський торговельно-економічний інститут Київського
державного торговельно-економічного університету, Ужгород, Україна

Резюме. Ефективність обробки рослинної сировини у збереженні хімічного складу і вітамінів потребує якісного підходу до процесу її обладнання, адже недостатня забезпеченість населення білковими продуктами харчування є актуальною проблемою. Сьогодні дроблення сировини валками визначається в основному, конструктивними та кінематичними параметрами й відповідно до валків ставляться досить суперечливі вимоги задля зменшення небажаного ефекту. Розкрито вплив конструктивних параметрів валків на мінімальні ризики на руйнування сировини (льону), оскільки в разі руйнування вона стає непридатною для використання за своїм складом, а також пошкоджує якість виробу. В ході досліджень встановлено, що валкові робочі органи якісно подрібнюють насіння льону. Це дозволяє слизеутворюючим полісахаридам переходити у рідку фазу тіста і не перешкоджати утворенню суцільної структури клейковини. Також встановлено, що необхідні реологічні властивості забезпечуються при внесенні до рецептури тіста подрібненого насіння льону в кількості 4–5%, збільшення кількості до 6% і вище призводить до погіршення органолептичних показників. Проведені дослідження встановили, що використання валкового дроблення льону не зменшує його хімічного складу. Необхідні реологічні властивості забезпечуються при внесенні до рецептури тіста ПНЛ у кількості 2–3%. Збільшення кількості до 4% і вище призводить до виникнення більшої вязкості. Оптимальним є використання ПНЛ в кількості 1–3%, що дає змогу збагатити склад тіста та підвищити його біологічну цінність, зберігаючи при цьому структурні та органолептичні показники, притаманні печиву. Використання добавки ПНЛ не впливає на тривалість випікання печива. Показав параметри можливого подрібнення насіння льону зі збереженням усіх його фізико-хімічних якісних властивостей. Напрямок подальших досліджень передбачає зв'язок інших властивостей дроблених дикорослих рослин на харчову цінність продукції.

Ключові слова: насіння льону, клейковинний каркас, клейстеризація крохмалю, полісахариди насіння льону, реологія, органолептика.

https://doi.org/10.33108/visnyk_tntu2024.02.051

Отримано 17.01.2024